

Life After Death Contact Experience between the Living
David Sereda and his deceased wife, Crystal Sereda - who died on August 9th,
2021



Crystal with the children at Chaco Canyon New Mexico – May 2018

The Greatest question I have after studying Near Death Experiences (NDEs) for over 30 years, is that do we exist inside the same universe and hence the same solar system, after death, but on a different vibrational level?

"Pythagoras experienced and taught that all the sidereal bodies were alive and that the forms of the planets and stars were merely bodies encasing souls, minds, and spirits in the same manner that the visible human form is but the encasing vehicle for an invisible spiritual organism which is, in reality, the conscious individual. Pythagoras regarded the planets as magnificent deities worthy of the adoration and respect of man. All these deities, however, he considered subservient to the One First Cause within whom they all existed temporarily, as mortality exists in the midst of immortality."

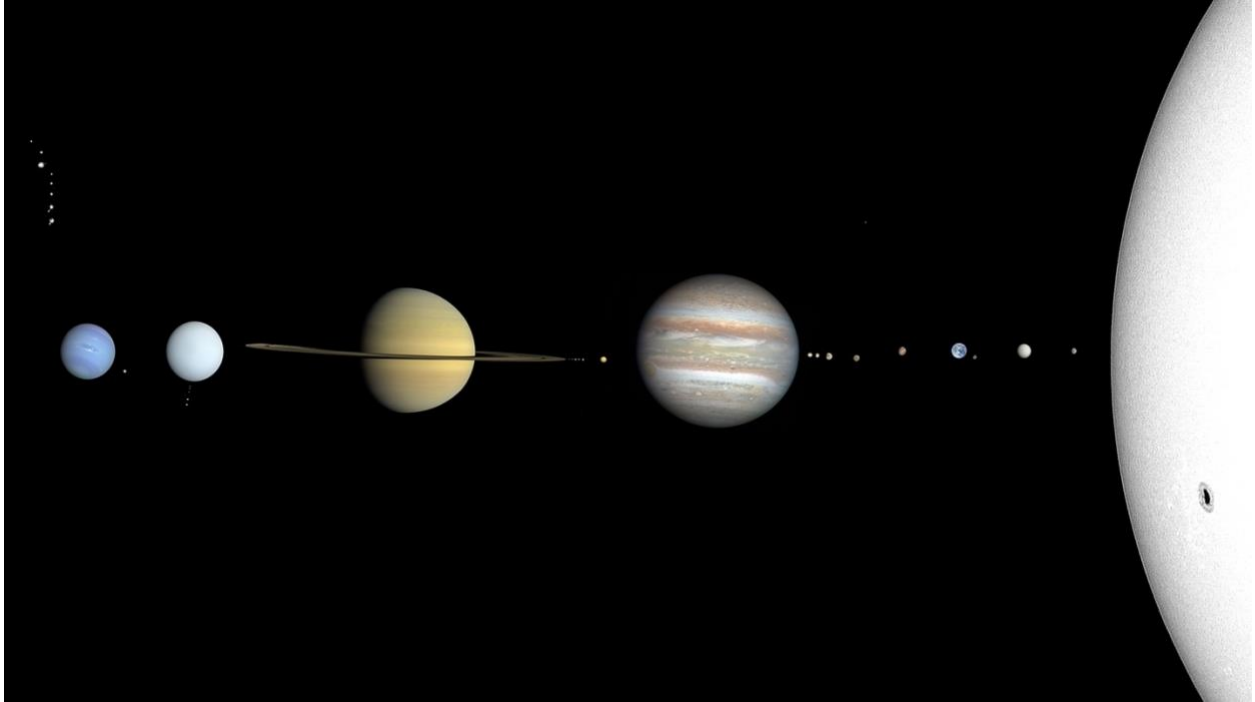

Could we still evolve after death in the solar system? Are the heavens right in front of us every day?

The Bible, Book of Job, 9, we can see that God's creation goes way beyond the Earth to the Stars and to creation "past finding out" or literally "invisible":

⁶ He shakes the earth out of its place,
And its pillars tremble;
⁷ He commands the sun, and it does not rise;
He seals off the stars;
⁸ He alone spreads out the heavens,
And treads on the waves of the sea;
⁹ He made the Bear, Orion, and the Pleiades,
And the chambers of the south;
¹⁰ He does great things past finding out,
Yes, wonders without number.

What is about to happen, is that my deceased wife, Crystal Sereda, will fulfill what the Greek Goddess Harmony set forth thousands of years ago with one simple number that will recalibrate our entire Solar System to the Golden Ratio! That number is 591!

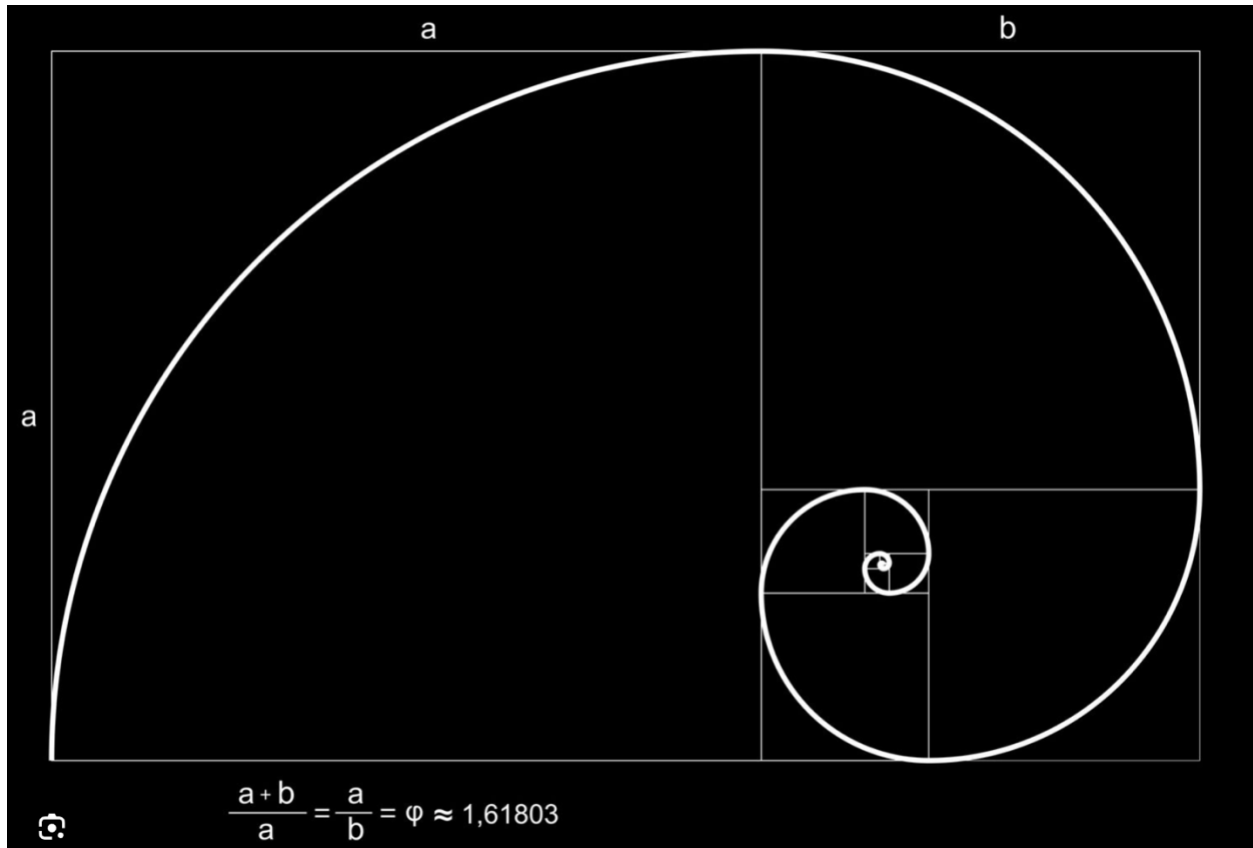

The Greek Symbol for “Harmony” is Phi, the Golden Ratio and the Goddess Harmony, the Goddess born of Venus (Aphrodite).

The Golden Ratio, also known as the golden number, golden proportion, or the divine proportion, is **a ratio between two numbers that equals approximately 1.618**. Usually written as the Greek letter phi, it is strongly associated with the Leonardo Fibonacci’s mathematical sequence, a series of numbers wherein each number is added to the last: 0,1,1,2,3,5,8,13,21,34 etc. 5 divided by 3 = 1 to 1.6666 - 34 divided by 21 is as 1 to 1.619 and so it keeps progressing until you get to 1.6180339887 and beyond.

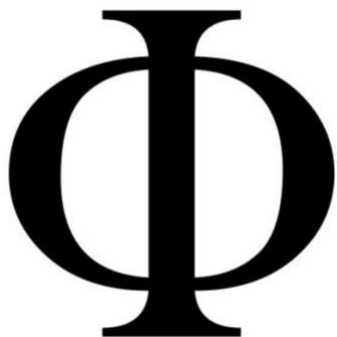

Leonardo Fibonacci (1170-1250) is a predecessor to Leonardo DaVinci (15 April 1452 – 2 May 1519) who studied ancient architecture and is noted for presenting the Fibonacci sequence that leads into an infinite expression of the Golden Ratio. His numbers divide into pairs that start at 1:1, 1:2, 2:3, 3:5, 5:8, 8:13, 13:21, 21:34 etc to infinity. They will reach and pass a ratio of 1 to 1.61803. Technically, they span most of the ratios found in music and in nature.

A 1:1 is a Musical “Unison” which can be expressed as a square or cube of even sides, such as the Cubic “Holy of Holies” in Solomon’s Temple.

A musical octave is a 1 to 2 or 2 to 1 ratio. That means an “A” $440 \times 2 = 880$ or 440 divided by $2 = 220$ Hertz or waves per second! This is equal to a Fibonacci 1:2 ratio!

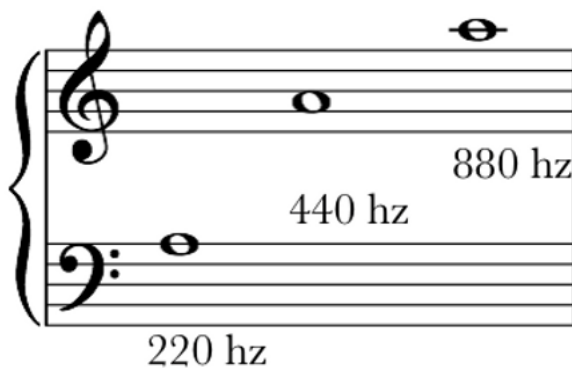

The Tabernacle of God was the first Temple used by the ancient Israelites to store the Ark of the Covenant and other holy objects to commune with God. The Holy of Holies was 10 x 10 Biblical Cubits where the Ark of the Covenant was stored. The Holy place was a 10 x 20 Biblical Cubit tent at the end of the Holy of Holies.

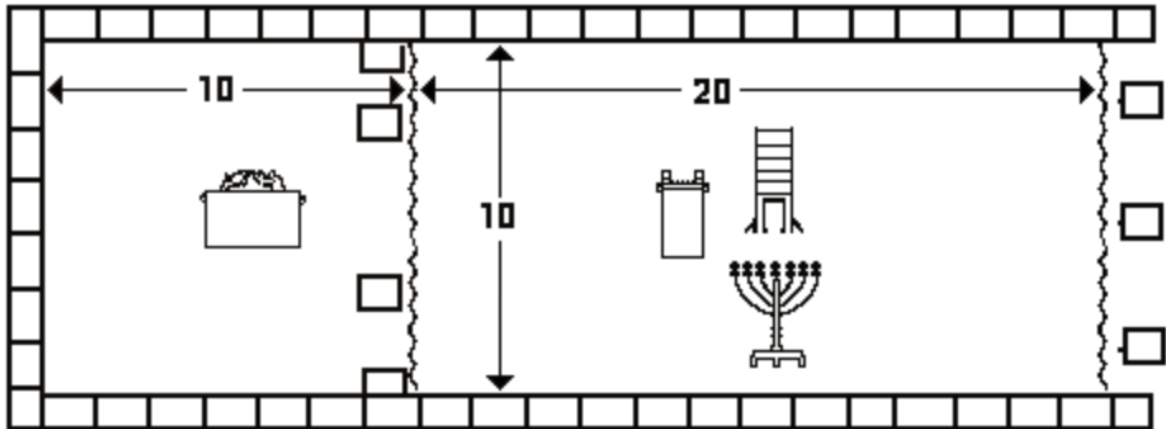

The Holy of Holies is a Fibonacci 1:1 ratio and the Holy Place is a Fibonacci 1:2 ratio, which is equal to a Musical Octave!



A Musical “Perfect Fifth” is a 3:2 ratio or 1 to 1.5 is also a Fibonacci 2:3 ratio!

A Musical “Perfect Fourth” is a 4:3 ratio, which is not Fibonacci! A Musical “Major Third” is a 5:4 ratio, which is not Fibonacci and neither is a Musical “Minor Third” which is a 6:5 ratio!

A musical Major 6th, is a 3:5 or 5:3 ratio, which is a ratio of 1 to 1.66666), which equals the ratio of the Ark of the Covenant! In music, it is Golden Ratio, or Fibonacci 3:5 in proportion! It is extremely close to the median Golden Ratio of 1 to 1.6180339887.

Who knew the Ark of the Covenant was designed after a musical Major 6th?
A Musical “Minor Sixth” is a 8:5 ratio or 1 to 1.6 – We will soon see the planetary spheres in our solar system are within tolerance of a Major Sixth or Minor Sixth – hence “Golden Ratio”!



The Ark of the Covenant designed by God in the Bible is a 3:5 ratio, as 1.5 cubits x 2.5 cubits is a ratio of 1 to 1.66666, which is an expression of the Golden Ratio because Fibonacci's 5:8 is a ratio of 1 to 1.6 respectively nearly identical to the proportions of the Ark of the Covenant, but Fibonacci's 3/5 ratio is 1 to 1.666666! Here we have evidence of the God of the Bible using the Golden Ratio to an accuracy of $1.618/1.66666 = 97\%$ - and respect to the whole sequence, we are within the Golden Ratio!

Considering the Exodus of the Jews with Moses was approximately 3,200 years ago, this is evidence of God using the Golden Ratio at that time period in God's instructions to Moses to build the Ark in Exodus 25:10-22.

There is an even more ancient temple where the Golden Ratio is used, and it has its own identical to the Tabernacle of Moses measurements in 2 of its inner chambers: The Great Pyramid of Egypt!

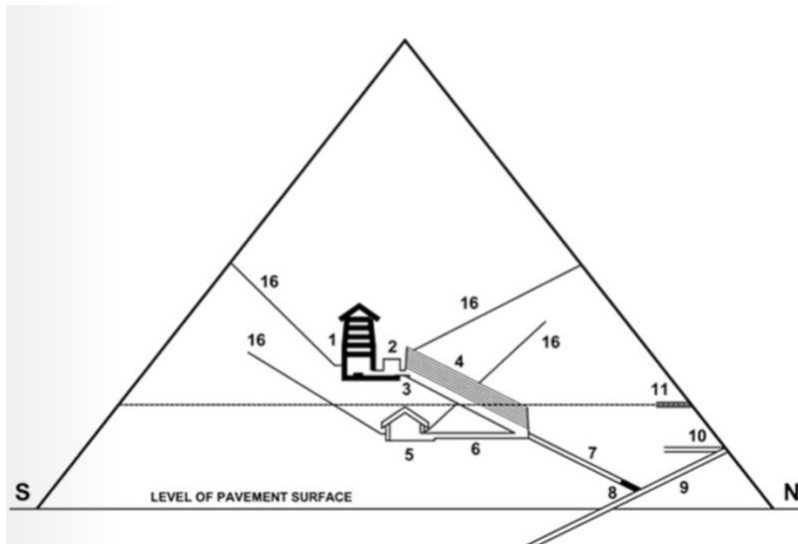

Just like the Holy of Holies of Moses being 10 x 10 cubits, the Great Pyramid Queen's Chamber is 10 x 10 Royal (Long Cubits). The Bible Book of Ezekiel 43:13 states that a Cubit of God is a Cubit "plus a hand" = a Royal Cubit or Long Cubit.

Just like the Holy Place of Moses being 10 x 20 cubits, the King's Chamber in the Great Pyramid is 10 x 20 Royal Cubits! Many scholars like Peter Lemesurier have argued that the Great Pyramid is the design of the God of the Bible and the Prophets!

The Holy of Holies "Queen's Chamber" is a 1:1 Fibonacci ratio while the Holy Place "King's Chamber" is a musical Octave 1:2 Fibonacci ratio!

The Great Pyramid's slope angle of 51.853972 degrees is created by making a Golden Rectangle!



Great Pyramid of Egypt Slope Angle created out of a Golden Phi 1.618 Rectangle

Remarkably, in tandem with the Shroud of Turin, tested to be the proven burial cloth of Jesus Christ, whose image is burned into the linen cloth by intense radiation no doubt, is the cloth that covered his face and received an imprint of his blood known as the “Shroud of Oviedo.” This second shroud was tested and proven to contain the same blood as that found on the Shroud of Turin.



Shroud of Oviedo Dimensions are 1 to nearly 1.618

The dimensions of this Shroud are stated as 84 by 53 centimeters, and thereby a ratio of 1 to 1.5849 or 98% of exact Golden Ratio! Wow! Who intentionally designed Jesus burial face cloth to be the Golden Dimensions?

The Sudarium (Latin for *sweat cloth*) is thought to be the cloth that was wrapped around the head of Jesus Christ after he died as described in John 20:6–7.

The Shroud of Turin is proven to be not imprinted by ink, paint or a burn by any form of fire that leaves a carbon imprint from the fire source. It is believed to have been caused by an intense form of radiation no less than high intensity ultraviolet light according to the Dr. John Jackson study! To really understand the shroud testing, I recommend reading:

https://discover.magiscenter.com/hubfs/MC_Spitzer%20Scholarly%20Articles/Science_and_the_Shroud_of_Turin.pdf?hsLang=en

The Shroud of Turin Linen fabric is 4.3 metres (14 feet 3 inches) long and 1.1 metres (3 feet 7 inches) wide for the 2 sides of the body. This makes each side panel of the front and back a 1:2 ratio, which is a musical octave.

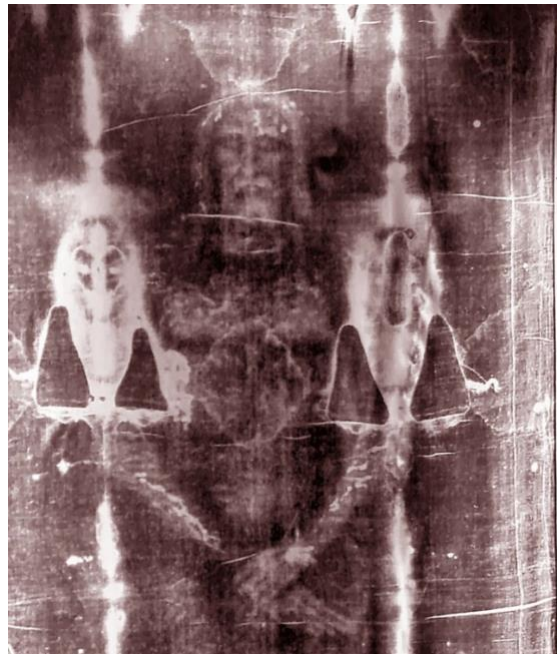

To establish the Golden Ratio of 1 to 1.618 respectively and lower and finer resolutions is going to provide the background for the key to the whole of the heavens and the solar system!

In a recent study on the human skull and 5 other mammal species, at John Hopkins University, 1.64 ± 0.04 and 1.57 ± 0.10) and approximate Phi Φ was proven!

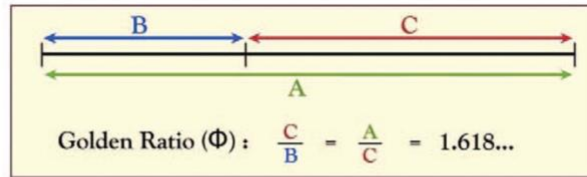

Cranial Measurements
Corresponding Ratio: $\frac{BI}{NB} = \frac{NI}{BI} = 1.6$

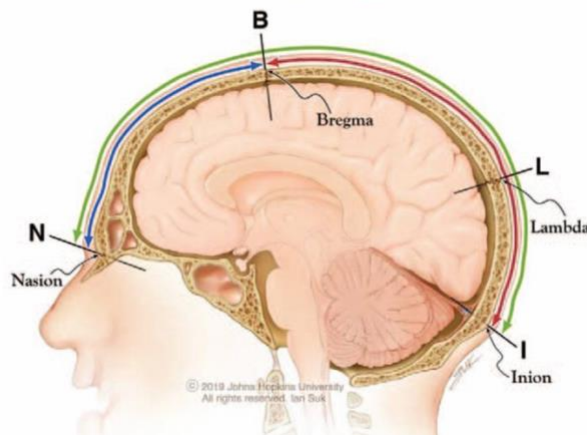

If the human design by God contains the Golden Ratio, what more do we need to proceed? See this study here:

https://journals.lww.com/jcraniofacialsurgery/Fulltext/2019/09000/Mammalian_Skull_Dimensions_and_the_Golden_Ratio.34.aspx#pdf-link

Golden Ratio revealed in speed of sound waves!

Sound moves at a faster speed in water (1500 meters/sec more or less depending on temperature and ocean depth) than in air (about 340 meters/sec) because the mechanical properties of water differ from air. Temperature also affects the speed of sound (e.g. sound travels faster in warm water than in cold water) and is very influential in some parts of the ocean. If we take the approximation in air, sound travels at 340 meters per second times the Golden Ratio 1.6180339887 cubed = (4.23606797710791)



Speed of Sound

Glenn
Research
Center

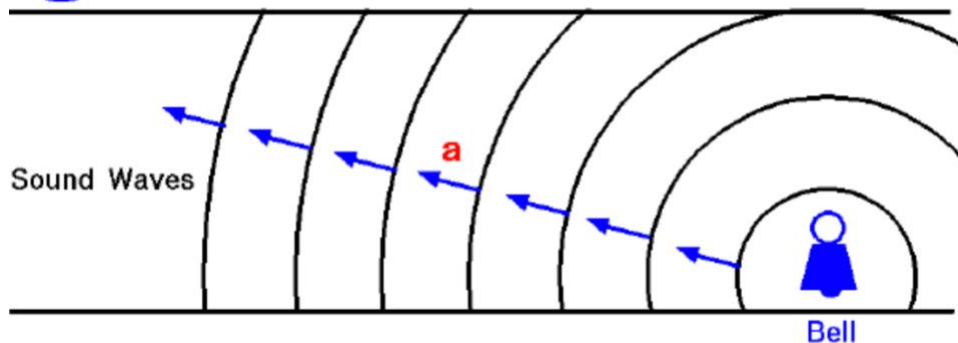

Speed of sound (**a**) depends on the type of medium and the temperature of the medium.

340 meters per second x 4.23606797710791 (Golden Ratio Cubed) = 1440.26311221668956 meters per second - is 96% of the approximate speed of sound in water again depending on temperature and ocean depth! This demonstrates a relationship to the speed of sound in air and water to the Golden Ratio Cubed! This means that at a certain temperature and ocean depth, sound will travel at 1440 meters per second! 144 is a magic number.

So if we take the speed of sound at 1440 meters per second at our magic water temperature x the Golden Ratio – “cubed” again, repeating the pattern, it equals: 1440.26311221668956 x 4.23606797710791 = 6101.052448270894923 meters per second, which is 98.34% of (6000 meters per second) the speed of sound in solid, which is an average because the speed of sound in solid materials varies depending on that material. This means that sound in air, water and solid are all a function of the Golden Ratio Cubed!

Think about how profound this is! The Median Golden Ratio rules the patterns and compositions in the natural universal design! Does it rule beyond this body, life and earth? We will discover that it does! Did the ancient Greek god Apollo, the god of music know this?



There is a scene in the marriage of Philology and Mercury, where the Greek Goddess Harmony comes into a wedding feast decorated in ornate gold attire with the God Apollo (an Olympian) and Pallas (Son of a Titan) accompanying her! Apollo is a God of Music and Pallas a God of Warcraft!



Harmony is holding a “Golden Wheeled” musical instrument, which has a series of ratio wheels within it that wells up a kind of music at the wedding fest that is beyond all instruments ever heard on Earth before this moment. She stuns her

audience. She describes its secret to be from the motions of the planets, which beckons her audience to the deepest of all musical secrets!

No one to this day has decoded the music of the Spheres of the planets of our solar system. Crystal Sereda, as a trained singer and musician, also an Orthodox Christian, was obsessed with the Goddess Harmony for a time during when we produced a segment in our documentary film “The Voice” about Harmony and the Music of the Spheres! Little did I know, after her death, she would communicate the lost secret, from beyond this life!



On the night of August 9th, 2021, my beloved wife, Crystal Sereda, tragically passed away on the anniversary of the nuclear destruction of Nagasaki in 1945. As she was taken from me in her last moments, I could hear her calling out to me through a static sound like an AM radio station coming from my staff beside our bed. Jesus proclaimed in Mark 6:1-8 that the Apostles had to have their staves with them upon dispersing them around the world to preach the Gospels and conduct Healings! My staff is made to perfection based on the Biblical Measurement codes and transmits frequencies 24 hours per day next to my bed! It appears to be acting like an afterlife frequency tuning devices, perhaps why Jesus insisted the Apostles carried their staves, so that he could keep them tuned to the afterlife frequency he would use to communicate with them. A staff, properly made and measured is a high frequency instrument!



My staff in the sun!

Hearing Crystal's frantic voice calling my name a few times, I awoke and hastily tracked the location of her phone, which revealed that it had gone way up into a mountain forested path. I was terrified. The next morning, I got our 2 daughters, Astaria (then 5) and Alyra (then 10), our Husky puppy, Halo and Crystal's Mom Ashley and we hiked up that trail. I had no idea if she left her phone up there, because this is a common daily hike for locals. It is about 1 mile steep upwards to a town lookout. Lots of people were coming down and no one seemed alarmed about anything. I had no reason to suspect the worst. When we got to the top, I found her pink purse set under a nice pine tree. Her cell was inside with a card that told us she had taken her life. I then looked over the steep edge of the cliff and saw her butterfly scarf stuck against the granite face of the massive cliff. I knew she was gone and we all just cried. The rescue of her body was a long process that Crystal's Mom dealt with while I got the children home to safety. It was a long hike down that trail of tears! The whole story of her death and the medications she was forced to take against her will for post partum illness is too private for this story!



After dealing with great trauma to our family, we came to Crystal's cremation! With great reverence, we collaborated with Jimmy Blanchette to honor Crystal's memory: powerful audio recordings of her musical voice were emitted on a harmonic antenna at 432 megahertz and 125,000 watts of power toward the Sun, the planets Mercury, Venus, Mars, Jupiter & Saturn. It was an incredible way to send off my beloved wife! Little did I know the message she would send back would confirm the harmony of the order of the planets. Why 432 megahertz?

Jesus and the 72 to 432 Secret code - Jesus had 72 disciples and 12 Apostles

Matthew has 27 Generations between King David and Joseph
 27×2 (Musical Octave) 5 Octaves = 432

The sun stops moving for 3 days during Winter Solstice (3 days of darkness)
The Radius of the Sun is 432,450 miles. Jesus said he will rise after 3 days (is he referring to the Sun at Winter Solstice?)
 $3 \text{ days} \times 24 \text{ hours} \times 3 = 72 \text{ hours} \times 60 \text{ minutes per hour} = 4320 \text{ Minutes} = 432 \text{ code.}$



Upon Crystal Sereda's cremation, we sent a treasured recording of her songs and our two daughter's voices to the Sun! A radio transmission requires 8 minutes and 21 seconds to reach the sun- the exact amount of time it takes for infrared light generated from our hearts and bodies to reach the sun. This is remarkable considering Crystal (born September 24th, 1979, at 8 pounds & 21 ounces) and I (August 21st, 1961 - or 8-21-1961) were coded with the Earth to Sun.

I tracked the days since her passing to see if any pattern had emerged, and it did. Astoundingly, night after night, she called my name—" David!" perfectly audible —exactly on the 9th of every month for several months. I shared details with our daughters Alyra and Astaria Sereda each time I was jolted awake by this occurrence. Every time the girls were around, they enthusiastically lit up and shared their stories. When addressing me, she spoke my name in a gentle voice that stood noticeably apart from any mental dialogue -- scarcely more than a few syllables yet perfectly audible.



One night, Astaria suddenly woke up and saw her mother, Crystal, in a luminous bright vision before her with a brilliant circle of light radiating from the top of her head to the soles of her feet wearing a luminous, shining, beautiful white dress. That's how my six-year-old daughter described the vision at that moment. Although I could not witness this phenomenon myself, as I watched her, she seemed transfixed by the vision until finally drifting off to sleep again.

Crystal called out my name in the middle of the night on precise intervals of time from the date of her death to that time and date. 234, 432, and 243 all share the same numerical elements. This is no coincidence as Crystal Sereda called out my name on these dates, occurring after her death by 234 days and 243 days, respectively.

On April 9th, 2022, 243 days after her death, we commemorated the 8-month mark since her passing, making this day a reminder to reflect on what lies beneath these figures: 432 being a harmonic frequency for an optimal middle "A" note that perfects our flawed 440 music scale, while 243 stands symbolically for Planet Venus, Dante's 3rd Sphere of Heaven.



Venus has a 243-earth day long Day and a 225-day Year

After I conducted my research, it came to light that Venus has the longest day-and-night cycle in our Solar System — taking a full 243.0226 Earth days for one rotation to experience one day and 224.7 Earth days to make one trip around the Sun! On top of this astounding fact, Venus also counter-rotates relative to Earth and all other planets. Venus spins “clockwise” from the top while the sun and other planets spin counter-clockwise looking from the North topology, yet Neptune may spin clockwise as well as Venus.

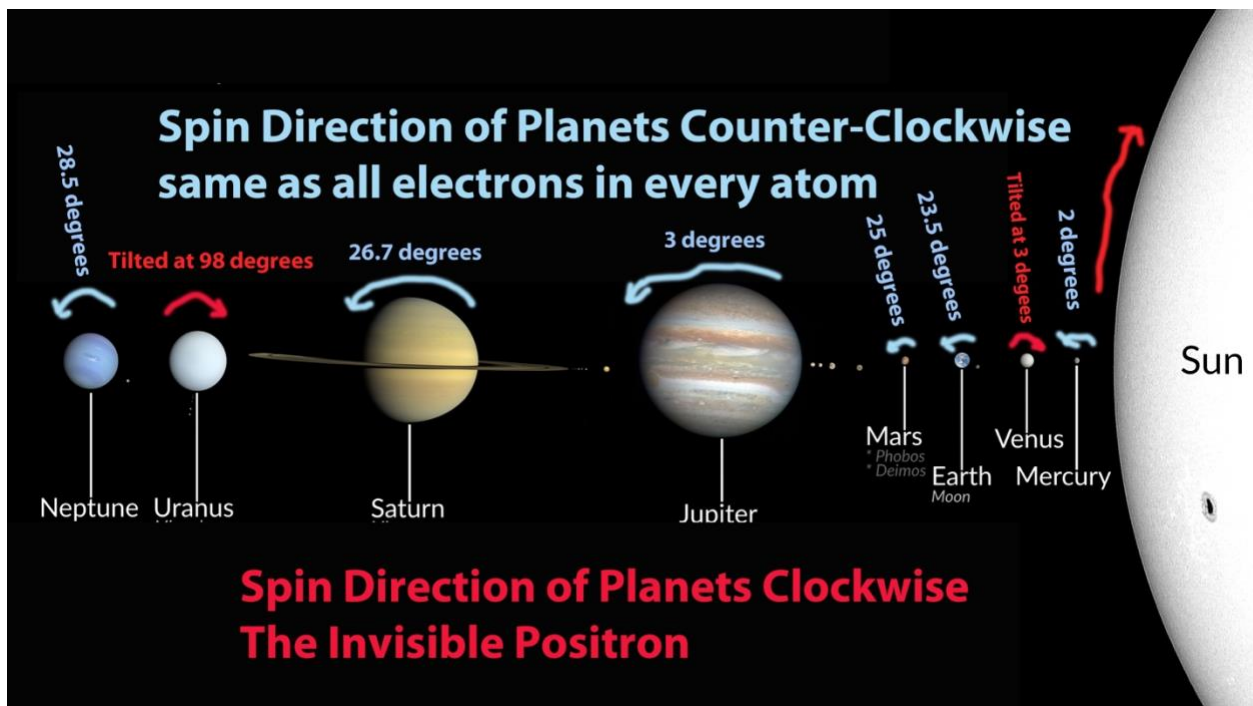

Furthermore, Dante's experiential system places Venus as its third level of Heaven— thus establishing an undeniable life-after-death connection between NDEs and the planet Venus. When my wife shared her story on what she saw after passing away - was she telling me she had gone to Dante's 3rd Level of

Heaven, Venus? This revelation left me astounded at just how much power lay outside our earthly confines!

My wife Crystal died August 9, 2021. December 25th to August 9 is 228 days, which is a near perfect harmonic of the Planet Venus 225 days. 225 is to 228 is 98.68% accuracy!

Consistent with Dante's observations, The Third Sphere of Heaven or Venus is the domain of all those whose love for God and mankind has earned them an eternal abode in paradise. In Dante's epic journey, he detailed his experiences across nine heavenly realms—from terrestrial Earth to lunar Moon and from the blazing Sun to Saturn in its orbit. He climbed through Mercury, Venus, and Mars before ascending further into Jupiter, Saturn and the glittering constellations of stars beyond it...and ultimately reaching Premium Mobile at peak!

In the Bible, 2nd Corinthians 12:21

I know a man in Christ who fourteen years ago was caught up to the third heaven—whether in the body or out of the body I do not know, God knows.

The Third Heaven is clearly Venus in order counting from the Sun, Mercury, Venus... but are the after-death “Heavens” truly within the same universe we live in now? That is the answer I was looking for, otherwise the empty planets would seem to be a waste of created mass with little to no purpose.

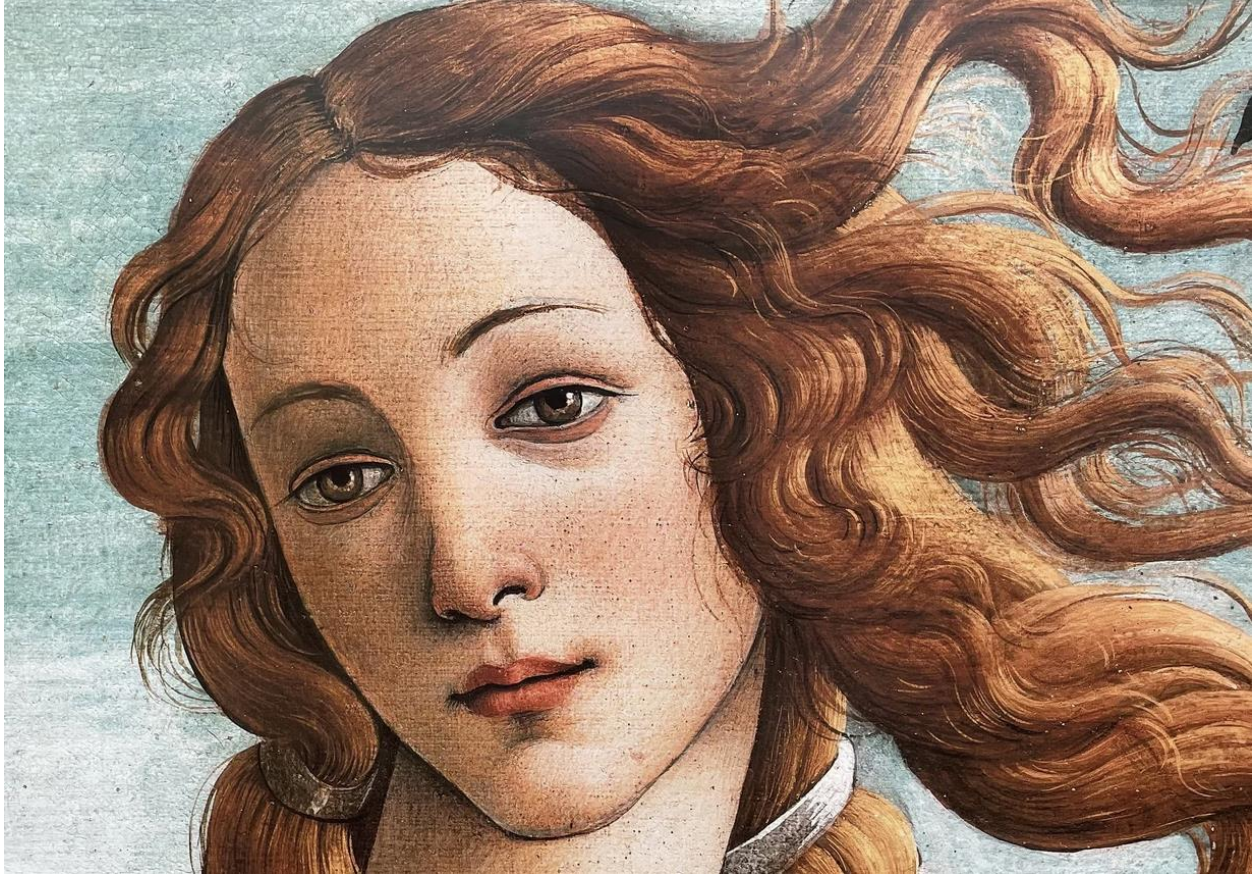

With the Goddess “Harmony” being the daughter of the Greek Goddess of Venus, and her musical instrument tuned to the rotation of the planets, a great secret will be revealed. A lot of time passed and I did not hear Crystal and thought contact had ended.

March 23, 2023 at 9:35:13 PM
7,901 of 8,408



Photo of Astaria Sereda awakened from her sleep right after I told her I just heard Crystal's Voice – Photo is dated at the top of image!

As I was drifting off to sleep in Banff, Alberta, Canada, during our family Spring Break vacation with Alyra and Astaria on March 23rd, 2023 = 591 days after her death - Crystal's voice rang out loud and clear at 9:30 PM Mountain time. Her voice was the most clear I have ever heard it. For decades, I have been obsessed with numbers, numerology, Greek and Hebrew Gematria, Pythagoras to modern physics! 9:30 was the exact time I heard her voice as I was jolted out of bed and marked the time. 9 goes into 30: 1 to 3.3333333333 times. That is an astounding ratio!

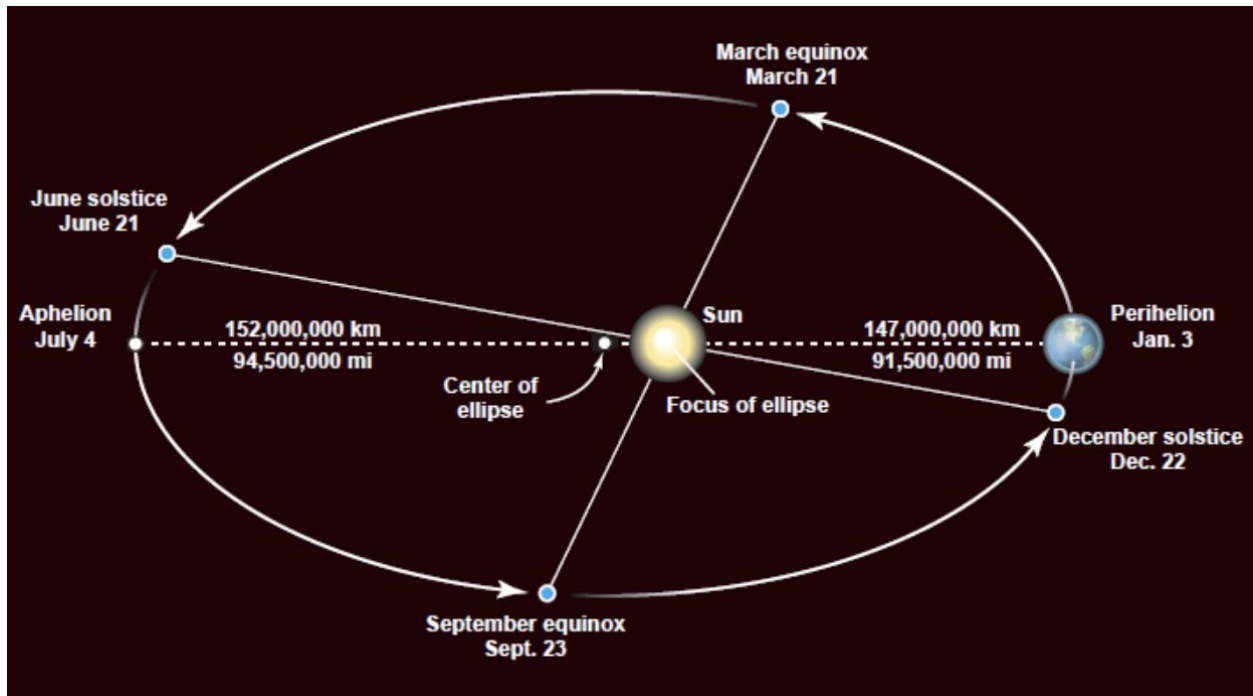

If we use the solar year start date at December 25th, the date that the sun moves 1 degree out of the southern cross constellation to begin a new year, it had been 89 days into the new year that Crystal called my name. That is a function of the planet Mercury's orbit at 88 Earth-days per year. How perfect as if Crystal timed her voice to a cosmic planetary time clock!

So we have 2 sets of numbers by date and time: one, is 591 days since she died, the other is 89 days into a solar year starting December 25th. 89 days being nearly 99% accurate to 1 Mercury year/orbit around the sun. Are the afterlife realms still using the "harmony of the order of the solar system?"

Mercury is the "messenger" planet equated to the Archangel Gabriel, the Greek Hermes, the Roman God Mercury - Messenger, so we are seeing evidence of life after death being within the harmony of the order of the solar system planetary bodies!



Arch Angel Gabriel, the Messenger equated to Mercury, the Messenger

We will soon discover just how on cue Crystal's message from beyond really is! Was I experiencing a quantum function called Einstein's "spooky action at a distance" from the other side?

August 9th, 2021 marked the day she passed away; we had counted 591 days until this momentous occasion. Her voice resonated deeply within the hotel room way above my mind, jolting me awake in a hotel room and sparking the potential of possibility throughout my body.

I then devoted myself to working out what was being communicated; first, by discovering the square and cubed root of '591', which seemed insignificant, then dividing it with Pi (3.14159) = (188.12) - nothing noteworthy appeared until I finally uncovered the answer!

It took me quite some time to understand the power of the Golden Ratio (1:1.618). When I finally did, it truly amazed me; I couldn't believe how these numbers manifested in reality! They revealed a world that Pythagoras, Leonardo Fibonacci, Leonardo DaVinci and Dante had envisioned centuries earlier - one full of life within our solar system's many levels of Heaven!

The Golden Ratio, also known as the divine proportion or "golden number," is a magical numerical relationship between numbers that can be expressed as 1 to 1.6180339887. This fascinating phenomenon has been associated with Leonardo

Fibonacci's mathematical sequence for centuries; in this series of numbers, each successive number equals the sum of its two preceding digits: 0,1,1,2,3... $5/3=1$ to 1.6666 - $34/21=1$ to 1.619, 1 to 1.618 and so on until you reach an infinite decimal point set at 1.6180339887+



Statue of Leonardo Fibonacci

Crystal spoke my name 591 days after her death, and when I did the math on that number $591/1.6180339887$ (Golden Ratio), it worked out exactly to be 365.25 - which is how long each year is in terms of days as given by the Julian calendar with 99.99% accuracy, and yet today we use the Gregorian Calendar that has to use leap years to make up for the error of 0.256363004 days per year!

If we take 591 divided by the exact Sidereal year of $365.256363004 =$ the perfection of the Golden Ratio 1.618041627363868 accurate to 99.999% of the fine Golden Ratio of 1.6180339887 – This is so astounding that Crystal could do this from the Other Side of this world to such accuracy! How did she do this? How and why did I notice?

Remember, the Golden Ratio is the symbol of the Greek Goddess “Harmony” and the Harmony of the solar system is about to be revealed with a whole new level of understanding never before seen or understood!



Tesla, later in life, seen adjusting a radio device in his lab.

Nikola Tesla astounded the world with his demonstration of radio waves travelling 1.618 times faster than the speed of light, with an accuracy of 98% and comfortably within the boundaries set by The Golden Ratio. By achieving this momentous faster-than-light transmission, he proved what Crystal had established: that there is a pattern to Time dimensions that follows The Golden Ratio - something so remarkable it was even patented in America!

On May 16th, 1900, Nikola Tesla applied for patent No. 787,412, demonstrating that his transmitter's current traveled across the planet at 292,830 miles per second. In contrast, radio waves moved with the velocity of light.

Tesla's scientific experimentation proved that a harmonious and proportional band of radio waves exists within the interplanetary medium. Various studies have fully confirmed this incredible discovery!

There are 2 ways to increase frequency: one is shorten the wavelength and the other is to increase the speed of light respectively as Tesla demonstrated!

What Tesla demonstrated is that this frequency harmonic Golden Ratio band actually exists in the interplanetary medium of radio waves. This is scientifically

proven! It means we could all be living in Golden Ratio Fractal Time dilation that separates our realities. This is a huge subject! In fact, there is a deeper possible reality to Crystal's message! We do not see anything in instantaneity, but rather in time. We see the sun as it was 8 minutes and 21 seconds ago. We see Venus 3 minutes and 46 seconds ago. We see the moon 0.65 seconds ago. What we see in front of our face, like a butterfly flapping its wings 1 foot in front of us, happened 1 billionth of a second ago. That means, everything we see is not in reality, but trapped in time! Think about what that means if we alter the speed of light like Tesla did. It means you see a different Time-based reality! Now, back to our reality!

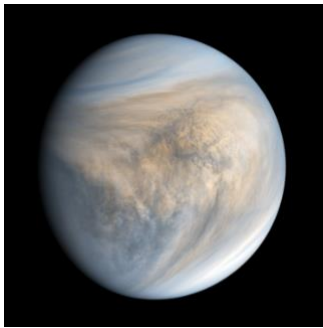

Applying the Golden Ratio of 1.6180339887 to the Earth 365.25 days per year yields 225.74 days, precisely how many days it takes Venus to orbit the sun in one Venusian year (99.54% accuracy). It takes Venus 224.701 Earth days to complete one rotation around the sun, so there is a tiny difference or tolerance. It's truly remarkable that my wife first called out my name after 243 days - a number related to Venus' single day and its orbital path around our Sun – and with this calculation, we were brought full circle back once more!

Venus appears to be the place from where God and the Angels observe Earth as Venus is the closest point to Earth next to Mars in the solar system. Not only do we have the Greek Goddess of Venus, we have Biblical reference to Venus by Jesus!

In Revelation 22:16, Jesus depicts himself as the "bright and morning star" Venus, renowned for its dazzling luminosity in the early dawn.



"I, Jesus, have sent my angel to testify to you about these things for the churches. I am the root and the descendant of David, the bright morning star."

Also, Lucifer or Satan is cast down from the height of the morning star (Venus) in Isaiah 14:12

"How you are fallen from heaven, O Day Star, son of Dawn! How you are cut down to the ground, you who laid the nations low!

As revealed in Luke 10:18, Satan fell from Heaven to Earth, indicating that God no longer would endure evil at the platform of Venus where He had been seated – the right hand of God. And he said to them, "I saw Satan fall like lightning from heaven."

In Revelation 2:27-28, we find that the Morning Star is a Gift from God and an area of glorious spiritual elevation.

He will rule them with an iron scepter and shatter them like pottery—just as I have received authority from My Father. And I will give him the morning star. He who has an ear, let him hear what the Spirit says to the churches....

Furthermore, we have the confirmation of Dante's experience and Pythagoras' writings that Venus is indeed the "Morning Star."

Intuitively, the early mathematician Pythagoras was one of the first to understand and recognize that both morning stars and evening stars are, in fact, Venus.

The Bible offers further insights into the role of Venus, with Jesus being linked to it as "the bright morning star." This gives us a clue that there could be more significance to Venus than we've previously thought. Moreover, it is right next to Earth and Mars on either side!

Is Crystal trying to tell me that she is living on Venus for the purpose of the proof of the spiritual model Dante and Pythagoras or is she telling me that the Revelation will play out from Venus as the platform where God's Angels will be launched to Earth from? I am still undecided because all I know is this message takes us to Venus with utmost importance and the Role the golden ratio plays in the Solar System and all life both physical and spiritual!

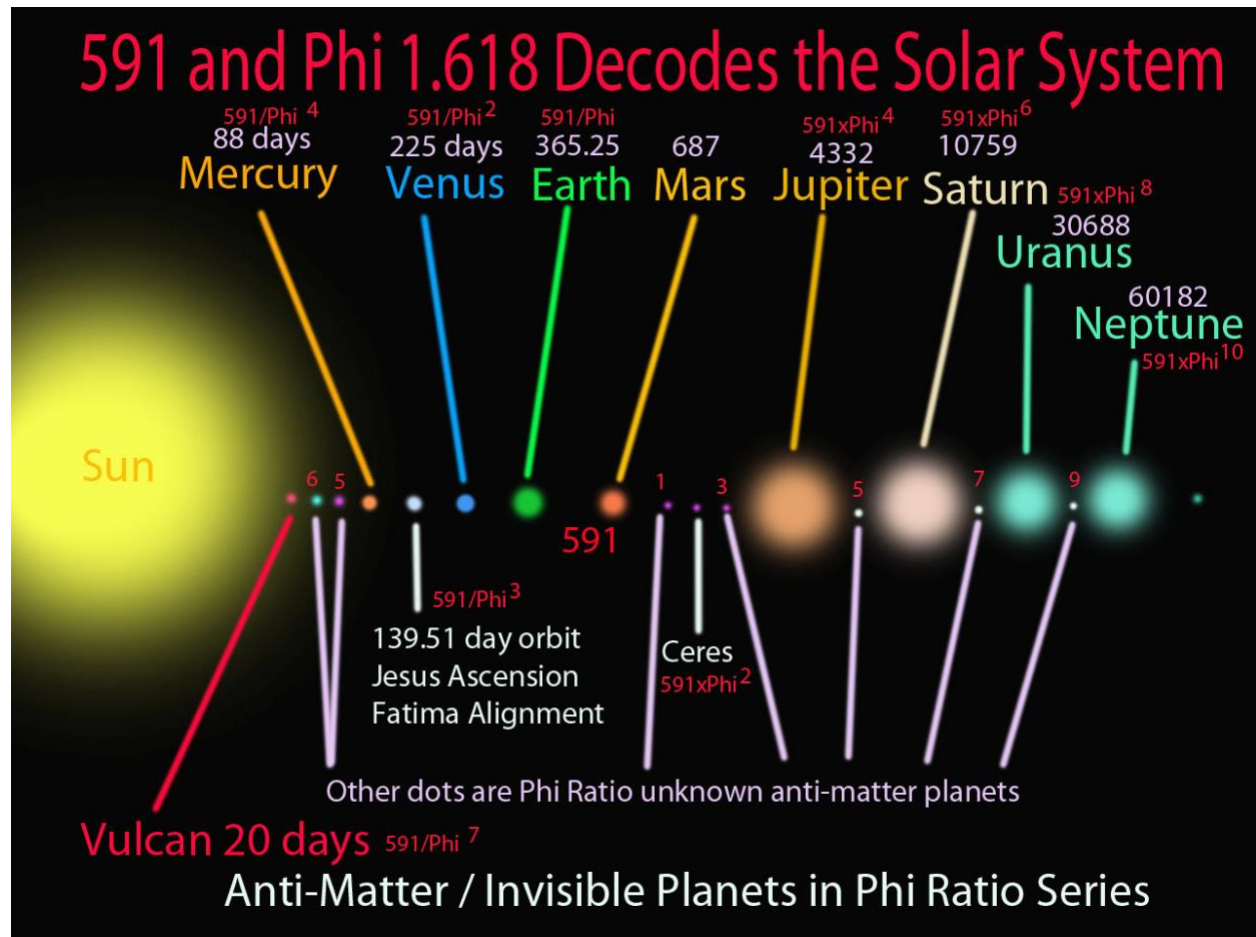

How does the 591 divided by the Golden Ratio confirm the other planets among the Heavens?

To discover how the Golden Ratio fractal time relationship applies to other planets in our solar system, I compared it against 591 days divided by and multiplied by the Golden Ratio with 591 being at the fulcrum of the solar system right next to Mars. My findings suggest a correlation between this number and many of these planets' days per year that are more precise than 90%. Amazingly, it was accurate up to 1:1.6180339887!

Additionally, it is worth mentioning that the Golden Ratio (Phi), similar to Pi (3.14159...), is an ever-growing and non-concluding formula based on Leonardo Fibonacci's sequence. So there is no 100% accuracy to it. It can range from 1 to 2, 1.5, 1.6180339887, and beyond. It never resolves and is continually expanding as Pi does! If we bear this thought in mind, we will gain an insightful understanding of our final destination after death.

This revelation comes from my late wife, Crystal Sereda - and she is hinting at a formula that involves some of the planets known to us, along with certain boundaries between them! By keeping this knowledge close to heart, the Heavens can be ours forevermore. For instance, the equation expands to include Mercury, Venus, Earth, Mars, Jupiter, Saturn, Uranus, and Neptune with a remarkable accuracy that allows each planet to sit comfortably within its range of the Golden Ratio.

Crystal's death was 591 days ago as to this new experience March 23rd, 2023. When we divide that number by the Golden Ratio four times, 86.223828789774765 days is revealed, corresponding to the 87.969-day duration of one Mercury year (98% accuracy). This incredible precision illustrates this ratio's power; it ranges from 1 to 1.5 or even greater than 1.6180339887! The Golden Ratio exerts tremendous influence in our universe.

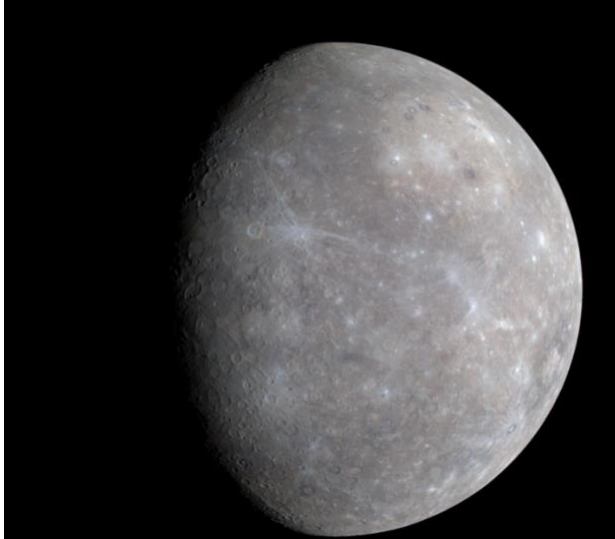

Photo of Mercury

We sent Crystal's musical recording to the planet Mercury (the Messenger, Hermes, Archangel Gabriel) on the antenna after she died on her birthday, September 24th, 2021. She would have been 42 years old.

You can see the video of the first transmission on youtube here:

<https://www.youtube.com/watch?v=Jxyi0P4XV-Q&t=5s>

We can musically tune our body-mind to the frequency and octaves of Mercury, Venus, Earth, Mars, Jupiter, Saturn, Uranus and Neptune at any time using my scaled systems of the frequencies of the Planets. The discovery of the “Music of the Spheres” was Pythagoras’ early work on developing music scales. Crystal and I had offered the frequencies of the planets long before she was ever close to death.

From Wikipedia:

The *musica universalis* (literally **universal music**), also called **music of the spheres** or **harmony of the spheres**, is a [philosophical](#) concept that regards proportions in the movements of [celestial bodies](#) – the [Sun](#), [Moon](#), and [planets](#) – as a form of [music](#). The theory, originating in ancient Greece, was a tenet of [Pythagoreanism](#), and was later developed by 16th-century astronomer [Johannes Kepler](#). Kepler did not believe this "music" to be audible, but felt that it could nevertheless be heard by the soul. The idea continued to appeal to scholars until the end of the [Renaissance](#), influencing many schools of thought, including [humanism](#).

So now, I would ascend to the planets beyond Earth by multiplying the base number of 591 by the Golden Ratio. Or, could 591 be Mars, which was Dante's 5th Level of Heaven, with the Sun being his 4th?

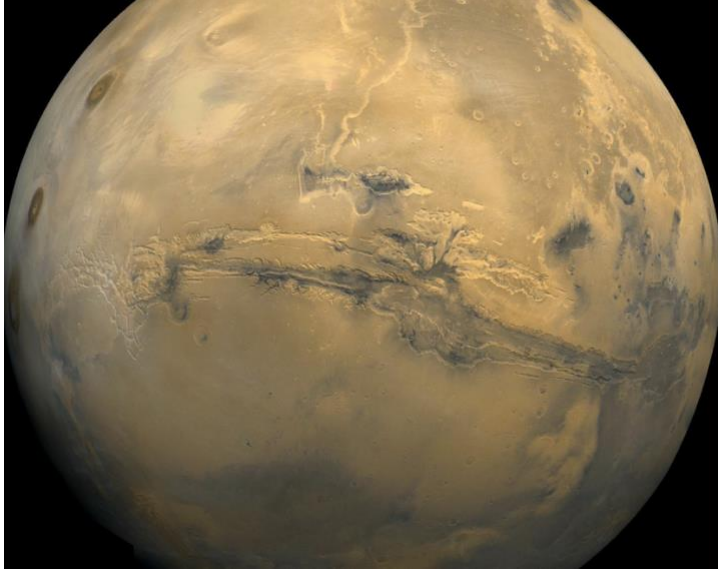

Mars with its mighty gash or blow

Currently, Mars has an annual orbit around the sun of 686.98 Earth days per year. It seemed far off. The accuracy for the Golden Ratio was 85%, (1 to 1.88), which puts it within the fringe of the Golden Ratio, but I was almost certain Crystal did not mean 591 to be Mars, or is there something about Mars that I am not considering yet? Why was Mars so out of the range? Did something displace it, or is tolerance to the harmony of the spheres allowed?

Astronomers have postulated theories mathematical that a planet or planets once orbited between Earth and Mars! Those orbiting spheres became unstable and resulted in massive collisions that destabilized this region!



Theia, in Greek Mythology, one of the Titans, newly discovered to be a planet nearly the size of Mars, with a prospective diameter a little smaller than Mars of 6,102 km, and Mars having a diameter of 6779 km, is now known to have been knocked out of its original orbit and collided with Earth 4.5 billion years ago!

Could 591 days have been the original orbital period for Theia or another solar system body in this region?

We will shortly realize 591 is the “Master Code” to the entire solar system. Without it, starting anywhere else, we could never decode the solar system to the harmony of the Golden Ratio! If we started with Mars as the fulcrum, 687 divided by 1.6180339887 = 424.5893502842707, 262.410649745006003, etc does not yield any harmony. 591 divided by 1.6180339887 = 365.258087362451214 (Earth), 225.741912662734421 (Venus), 139.516174715282371 (missing planet), 86.225737957072107 (Mercury), etc. 591 yields a nearly perfect harmony!



Dwarf planet Ceres with mysterious bright spot!

$591 \times \text{the Golden Ratio } 1.618033988749895 - 2 \text{ times} = 1547.258087351188146$ days. If we compare this to the asteroid belt between Mars and Jupiter, and the dwarf planet Ceres, which has an orbit around the sun of 1,682 Earth-Days per year, it is 92% accurate to the Golden Ratio. This would mathematically postulate that the asteroid belt was due to a collision that destroyed possible a number of planets between Mars and Jupiter!

$591 \times \text{the Golden Ratio } 1.618033988749895 - 4 \text{ times} = 4050.774262053565086$ days. If we compare this to Jupiter's 4332.59 Earth-Days per year, it is 93.5% accurate to the Golden Ratio, which is stunning accuracy because it is well within tolerance of the expanded range for the Golden Ratio series of numbers.



Jupiter image from James Webb Telescope

Jupiter is the 6th Level of Heaven in Dante's recorded system, as it is the 6th level in this system. In the Greek/Roman, Jupiter/Zeus is the King of the Gods!

$591 \times 1.618033988749895 - 6 \text{ times} = 10605.064698809508812$ days. If we compare this to Saturn's 10756 Earth-days to orbit the sun, we are 98.6% accurate to the Golden Ratio still. This indicates that 98.6% remains consistent with the Golden Ratio criteria! This is astounding because our formula starting with 591 is not drifting away from the golden ratio, rather, it is coming back to perfection!

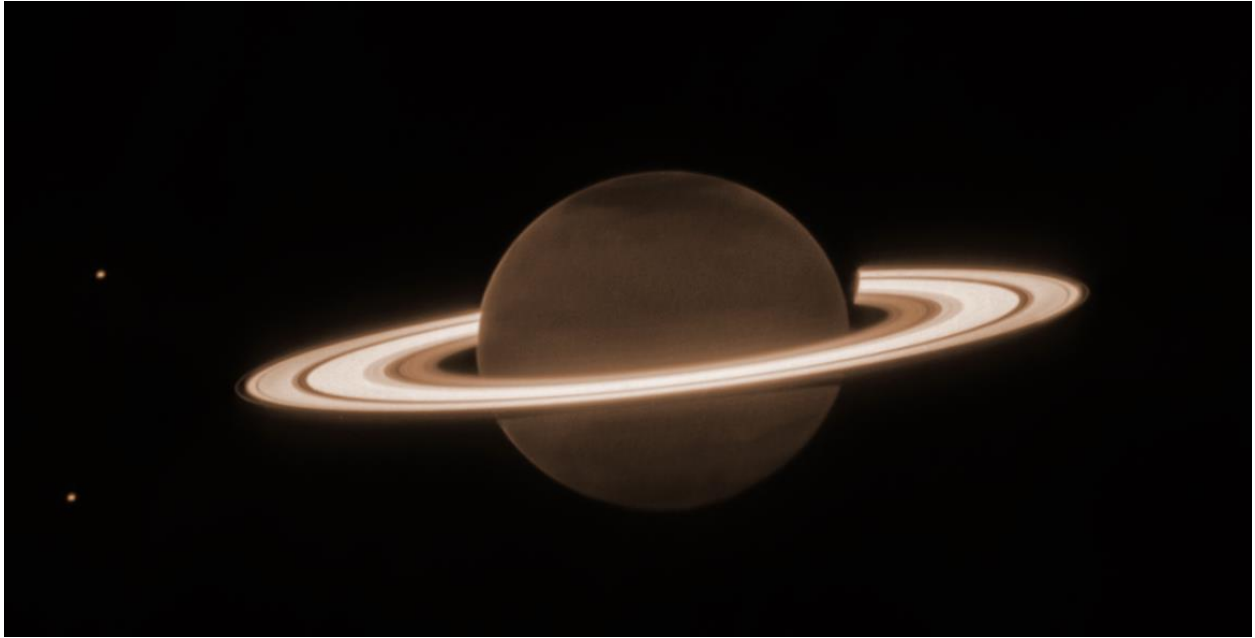

James Webb Telescope image of Saturn

Saturn is the 7th Level of Heaven in Dante's recorded system, and Cronos, Saturn in the Greek/Roman system! This again is stunning!

$591 \times 1.618033988749895 - 8 \text{ times} = 27764.419834374965799$ days. If we compare this to the Planet Uranus' 30,687 days per Earth-year, we are 90.47% accurate in harmony with the Golden Ratio!



James Webb Telescope image of Uranus with its moons

Uranus is not in Dante's system. At the 8th, he goes to the star constellations! Uranus, in the Greek mythology, is the personification of Heaven, Son and Husband of GAIA, Earth.

$591 \times 1.618033988749895 - 10 \text{ times} = 72688.194804315400233 \text{ days}$. If we compare this to the Planet Neptune's 60,190 days, Neptune 82.8% accurate to the Golden Ratio, still within tolerance. This would put Neptune in the range of accuracy similar to Mars, if Mars was indeed 591.



James Webb Telescope image of Neptune

In the Greek mythology, Neptune is Zeus' brother, Son of Cronos and Rea!

$591 \times 1.618033988749895 - 110 \text{ times} = 117611.969774255840492$. If we compare this to Pluto's 90582 Days, Pluto is only 77% accurate, and falls way out of line with the Golden Ratio model. It is no longer believed to be a planet and must be a remnant of the massive collision that caused the asteroid belt to appear and the damage to the perfection of the Original Harmony of the solar system!

However, the dwarf planet "Makemake" has an orbital period of 111,845 days beyond the orbit of Neptune and Pluto; and it is 95% accurate to the $591 \times 1.618033988749895 - 110 \text{ times} = 117611.969774255840492 \text{ days}$! To be 95%

accurate this far from the Earth is astounding to say the least! There are a number of dwarf planets in this outer region of the solar system.

$591 \times 1.618033988749895 - 111 \text{ times} = 190300.164578571265397$ days. We compare this to dwarf planet Gonggong which has an orbit of 202,484. This even has an accuracy of 94% - and we are still holding within our Golden Ratio way beyond the orbit of Pluto. Remember, Pluto was only 77% accurate. These last 2 dwarf planets have come back into the harmony of the order of the Golden Ratio! How?

Dwarf planet Eris has an orbital period of 204,199 days which puts it very close to Gonggong! Eris is still at 93% accurate to our Golden Ratio model.

Sedna is a dwarf planet in the outermost reaches of the solar system. It was discovered in 2003. It's orbital period is 4160197.5 days and that is even if astronomers are anywhere near accurate for such a distant object. It comes in at 82% accurate to the Golden ratio formula and that is still better than Pluto.

This indicates that we have received a transmission from beyond the grave, providing evidence of Life after Death in our very own universe. Furthermore, the Golden Ratio Fractal Time Dimension contains an equation that explains how and why this occurs, furthering our understanding of life on other planets within our solar system!

The question remains if tolerance to the harmony of the perfection of the Golden Ratio is intentional, or was there a "war in the Heavens" as many great myths contend, such as the war of the Titans and the Olympians?

The final confirmation of Venus appeared:

The majestic planet Venus takes 224.701 days to complete one lap around the sun, and when compared to Earth's 365.25636-day year period, it yields a ratio of 1: 1.625521737775978 - firmly in line with the Golden Ratio range for ultimate perfection! Suppose we multiply by 365.25636 and 0.615187097631921, respectively. That results in 593.732153040928167, amazingly 99.539% accurate to the point to my wife speaking from beyond after precisely 591 days since her passing - proving she is likely residing on the Spiritual Plane of Venus now! This occurrence can't be due to Mars' 687-day orbit cycle, which Dante labeled his 5th Sphere of Heavens, unless there is something I am missing still.

As Pythagoras realized, we are all spiritual beings inhabiting the many planets in our system. My wife's presence and connection serve as continued evidence for this truth to me. Additionally, it reminds us that so much awaits us at the end of our earthly journey!

If I divide the Earth year again by the Golden Ratio $1.6180339887 = 225.74$ Days, which is the number of Earth days it takes Venus to orbit the sun in 1 Venus year (225 days) accurate to 99.67%. The Fact that my wife started by calling my name with the number of days for Venus to experience a day (243) and we come back to Venus with the Golden Ratio experience again is utterly remarkable.

So even though we have Dante's experience, we also have Pythagoras' confirmation on Venus being the "Morning Star"

The early mathematician Pythagoras was one of the first to recognize that the morning and evening stars were actually the same object: Venus.

We also have Biblical accounts of the role of Venus that surpass what Dante describes! Jesus clearly has a platform in the Spirit on Venus, "the bright morning star." That gives Venus more importance than we can imagine. It is also right next to Earth as is Mars on either side!

We sent Crystal's musical recording to the planet Mercury (the Messenger) on the antenna after she died on her birthday, September 24th, 2021 she would have been 42 years old.

What all of this means is that we have contact from a deceased person who gave humanity the formula of Golden Ratio Fractal Time Dimension "Evidence" that Life after Death occurs in the very same universe we live in, ever expanding our lives on the known planets of our solar system!

Pythagoras also experienced that we live as spiritual beings on the known planets within our system. I believe for myself anyway that my wife's experience with me makes me believe this is true. We have so much to look forward to on our journey after death on Earth!

This testimony came in from George Shields, after hearing me on a podcast about this experience. If we take his two dates, the time lapsed after his Mother's death and the time he heard her voice was 592 days x 2, so that is exactly 2 Venus to

Earth Years. (Venus 225 + 365.25 Earth = 590.25) so 592 to 593 is 99.83% accurate to an Earth to Venus year. Here is what George Shields attested to me:

George Shields, an electrical engineer, aged 65, from Ontario, Canada, Hi David hopefully you see this message. When watching the last Lazarus and you explained the calculations re timing with your wife's voice, I was amazed so I heard my Mother Phyllis Shields, voice answer a question I was asking during meditation to the universe, "how do I connect" and my deceased Mother was crystal clear and audible, "George, you are already connected." She passed Dec 21st 2019 and I heard her voice March 20th 2023. If I did the math right the way you explained it then this is exactly 2 Venus to Earth years. Just amazing to say the least!

March 20th was also Spring Equinox for Canada this year of 2023.

The story gets deeper on the night of March 30, 2023. I wrote our family friend Stephen Cipes, who is the owner of Summerhill winery in Kelowna, BC where organic/biodynamic wines are aged in a huge pyramid that models the Great Pyramid's math to a high degree of accuracy. Stephen understood all of this as he read my experience with great enthusiasm. He came with his wife, Ria Cipes and daughter Esther Cipes to our family right away after Crystal died and stayed with us to comfort our family for several days.

Stephen and family came to Nelson, BC to visit us on March 30th, 2023 and invited us to dinner at 6:00 PM. After dinner, he invited myself, my two daughters Alyra and Astaria and Crystal's Mom Ashley to his room with family. We stepped out onto his balcony and to our astonishment, Venus was shining brighter than I had ever seen in in my lifetime. It hovered right above the cliff where my wife Crystal died in the darkness. We were all in awe on how the weather, timing and location of this event manifested for all of us. I also noticed the star system Pleiades was just above Venus. I took photos and video of this to confirm.



See Pleiades just above Venus (lower bright spot) and a mysterious comet!

It turns out, there is a great alignment of 5 planets going on right at this time noted by the press and astronomers. Could this all be a coincidence or a great Co-Incidence? January 1 to March 30 (the date of this experience) is 89 days, a nearly perfect function of Mercury's 88-day orbit around the sun! How could this all have aligned as such?

New Insight about Mars and the Great War in Heaven after being on Richard C. Hoagland's show April 9, 2023 (Easter 2023) and the 'War in Heaven.'

From NASA: On Feb. 7, 2021, Mars passes solar longitude 0 as the Sun crosses the equator on Mars. This is the vernal equinox, and was chosen by planetary scientists as the start of a new year (a Mars year is 687 Earth days).

591 is to 687 in the Golden Ratio 86% accurate - which means whatever caused the huge gash on Mars knocked it out 14% of its original orbit, which would have been

prior to the gash that sucked out its entire atmosphere and everyone living on it - this is the War.

That would mean my first message from Crystal was Venus as per 243 Earth days per Venus Day and 225 Earth days per Venus Year as of April 9, 2022 when I heard her voice - and that I did this show with Richard C. Hoagland last night April 9, 2023 (Easter 2023) - Easter in 2022 Was April 17 -

The new message from Crystal is Venus to Earth to Mars (original position) at 591 earth days per year.

Mars is Dante's 5th Level of Heaven !

I also realized that Venus is slightly out of its original alignment to the Golden Ratio so the “War in Heaven” knocked all of the planets out of alignment to the perfect harmonic of the Golden Ratio – some more and some planets less. The math proves it:

591 days (The Original position of Mars) divided by 1.618033988749895 (accurate to the 300th Fibonacci Sequence) comes to 365.258087351187821 Sidereal Earth days per year. NASA shows 365.256363004 Sidereal days per earth year. This means the original Mars position to Earth is accurate to 99.999%

Now we divide 365.258087351187821 sidereal Earth days per year by the Golden Ratio again $1.618033988749895 = 225.741912648812102$ Venus-Earth days per year accurate to 99.67% (Venus is out 0.33%) because Venus has 225 Earth days per year.

Now we divide 225.741912648812102 Venus Earth days per year by the Golden Ratio $1.618033988749895 =$ Our missing Planet is supposed to be at 139.516174702375671 Earth Days per year. We need to check what the War in Heaven did to this sphere!

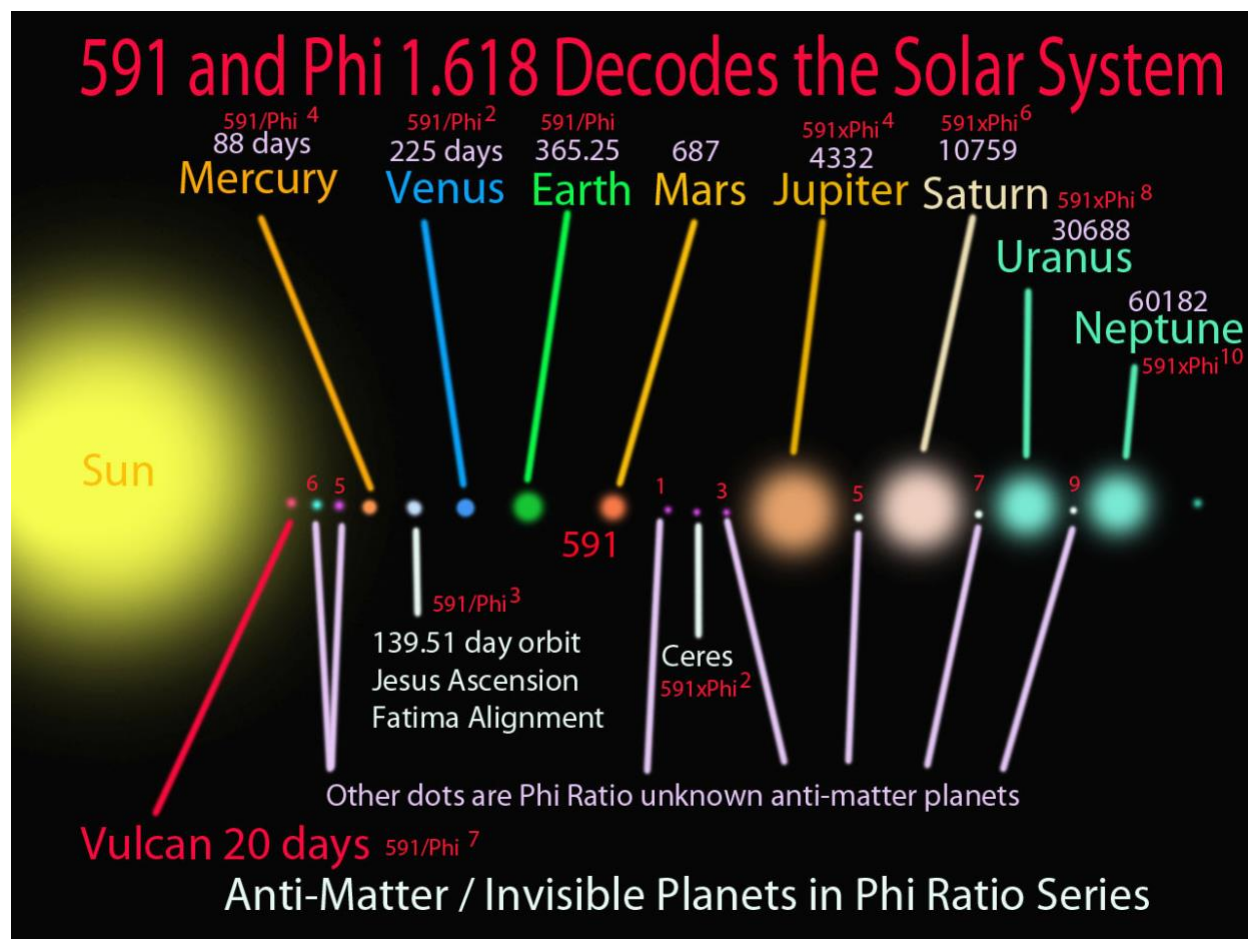

Amazingly, it turns out that Jesus' Ascension Day, 2023 is May 18 and the 21st for the Western Churches – which is 139 days after January 1st, 2023, which makes the 21st the 139th day of the year exactly. Remember, to be within the Golden Ratio, we do not have to be exactly at 100% accuracy because the Golden Ratio varies throughout its progression as does Pi! For the Orthodox, it is May 25th - That means Jesus' Ascension Day fits perfectly with the period of 1 solar orbit with our missing planet between Venus and Mercury!

Why was Jesus Ascension in perfect alignment with this missing sphere or body unless it was a station or heavenly body in our solar system? This opens up a huge discussion of possibilities! Could the planet Heaven be vibrating at such a high frequency that it remains invisible to our telescopes, yet it orbits the sun at approximately 139.51 days?

Did Jesus and the Prophets ascend to Heaven in harmony to the missing planet with a hidden orbit of a median of 139.51 days around the sun?

139 days reveals the greatest secret TRINITY: If we start at Jesus' Birthday in Urantia, August 21st + 139 days = January 7th, which is Orthodox Christmas Day. The earliest Christians on record celebrated Christmas as the day Jesus was Baptized and Received the Holy Spirit on Jan 6th and the 7th. We must note the Orthodox Church is older and predates the Catholic Church. Now if we move 139 days after January 7th, we come to May 25th, which is the date of Jesus Ascension in the Orthodox Church for 2023. This is utterly astounding accuracy!

We have to start at August 21st plus 139 days for this formula to reveal Jesus Baptism date of January 7th and plus 139 days again to arrive at his Orthodox Ascension date of May 25th. Could August 21st be his real birthday and Christmas is the celebration of his real birth in the Holy Spirit as the Original Book of Matthew tells? Whatever the mystery, August 21st has to be an important date.

January 7 to May 25th is 139 days, accurate to 139.516174702375671 days as the orbital period from January 1st into a calendar year to 99.63% of our Golden Ratio formula. This is still a high degree of accuracy according to our model!

In fact, we could start at January 7th as Orthodox Christmas Day minus 139 days and we arrive at August 21st. Once again, we start at January 7th as a mid point plus 139 days and we come to May 25th, the Orthodox Ascension day of Jesus for the year 2023, the very year this discover was made! May 25th is 144 days into the Calendar year from January 1.

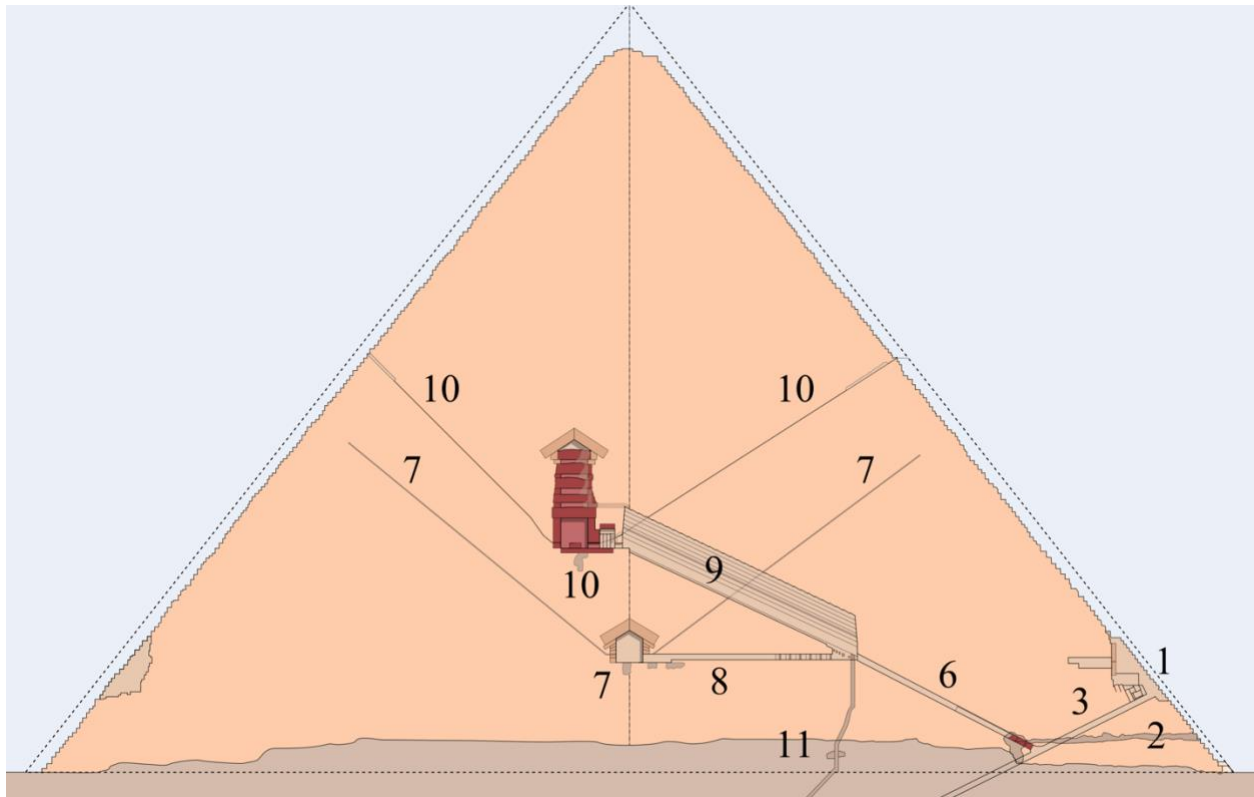

If we take the height of the Great Pyramid without its missing capstone, it would be nearly exactly 139 meters. It is arguable by a tiny percentage among many experts. Why 139 in metric?

The Great Pyramid finished height at 480.69 feet to its apex using precise mathematics, with a capstone would convert to 146.514312 Meters. If we convert January 1st to May 25th Orthodox Jesus Ascension Day at 144 days, we can see we are still accurate to 98.28% accuracy!

This absolutely ties in the Great Pyramid to the code of the Jesus ascension planet, or what very well may be the planet “Heaven” !

In Acts 4:10-12, Jesus refers to himself as the missing capstone/cornerstone that the builders rejected in his new resurrected body!

let it be known to you all, and to all the people of Israel, that by the name of Jesus Christ of Nazareth, whom you crucified, whom God raised from the dead, by Him this man stands here before you whole. This is the ‘stone which was rejected by you builders, which has become the chief cornerstone.’ Nor is there salvation in

any other, for there is no other name under heaven given among men by which we must be saved.”



Photo of Jacinta (one of the children who saw Mary) being carried!

The Miracle of the Sun at Fatima, Portugal, 1917

The Miracle of the Sun at Fatima on October 13th, 1917, might have been a flashing of super light coming from the Ascension Planet of Jesus (139.51 day orbit) and perhaps the Prophets. When Mary, the Mother of Jesus “appeared” in a vision to the 3 children at Fatima, Portugal in 1917, the first day of the apparitions was May 13th 1917. January 1st to May 13th is 133 days into the year. 133 days is to 139.516174702375671 days 95.3% accurate well within Golden Ratio tolerance. If we take January 1st is meant to line up with the new sun in a sidereal year as a baseline that drifts every year from this baseline date as does Easter and the Ascension date every year. This means January 1 to the start of the new sun each year is not 100% accurate at all.

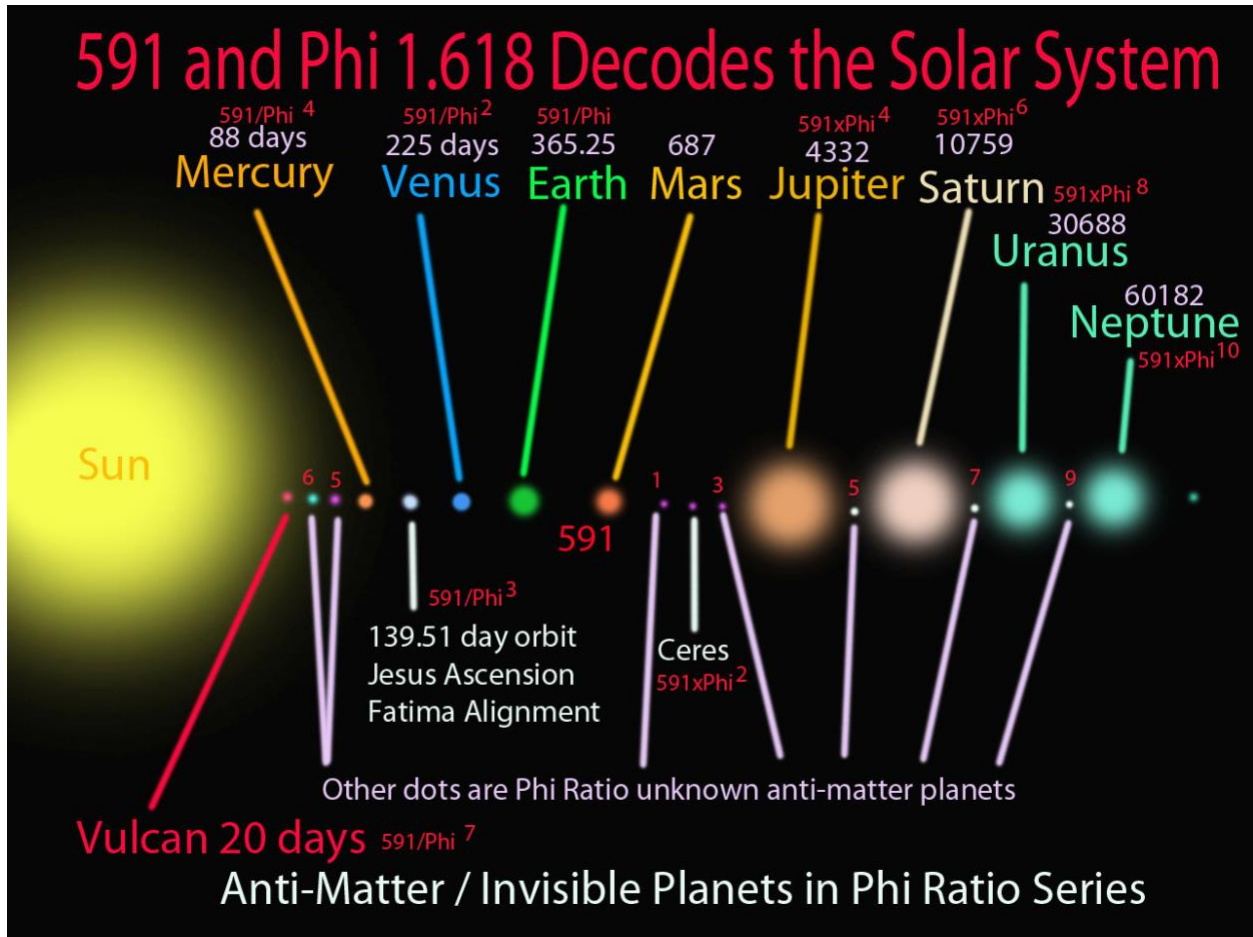

If we start at the date of Christmas day, December 25th as the new year based on the “new sun” suggested to me by experimenter/researcher Theo Davies, and count to May 13th, the day of Mary’s first apparition, it is exactly 139 days. That is utter perfection to the ascension planet at better than 99% accuracy. How can anyone ignore the accuracy of this mathematics?

BIBLICAL PROOF

Heaven is a real place described in the Bible. The word “heaven(s)” is found 276 times in the New Testament alone. In the Greek New Testament, “Heaven” is “Ouranos” is mentioned 278 times. The planet Uranus is Greek for “heaven”. Guess what that means in my model?

It is 278 Divided by 2 orbits = 139 to 2 orbits of Planet 139.51

The word “angel” appears in the King James Bible 285 times

285 divided by 139.51 = 2.04 or 98% of 2 orbits of planet 139.51 – Can people see that there is now overwhelming proof of just where heaven is?

The Miracle of the sun October 13th, 1917 was 2 orbits of Planet 139.51

The now famous “Miracle of the Sun” at Fatima, Portugal, on October 13th, 1917, was now 285 days from January 1st. That is nearly and precisely 2 orbits of the Ascension Planet around the sun: $139.516174702375671 \times 2 = 279.032349404751342$ days to be exact. This is 98% accurate to the date of the “Miracle of the Sun” which means we now know for certainty that this ascension planet is as real as Earth and Venus, yet it eludes us as being invisible, cloaked, or being an anti-matter planet that can pop in and pop out of visibility due to it’s energy state. This is the planet know as Heaven and we are on Earth.

Again, Theo Davies suggested December 25th, Christmas Day, to October 13th is 292 days, which is almost 98% accurate to 2 orbits of the Ascension Planet $139.516174702375671 \times 2 = 279.032349404751342$ days.

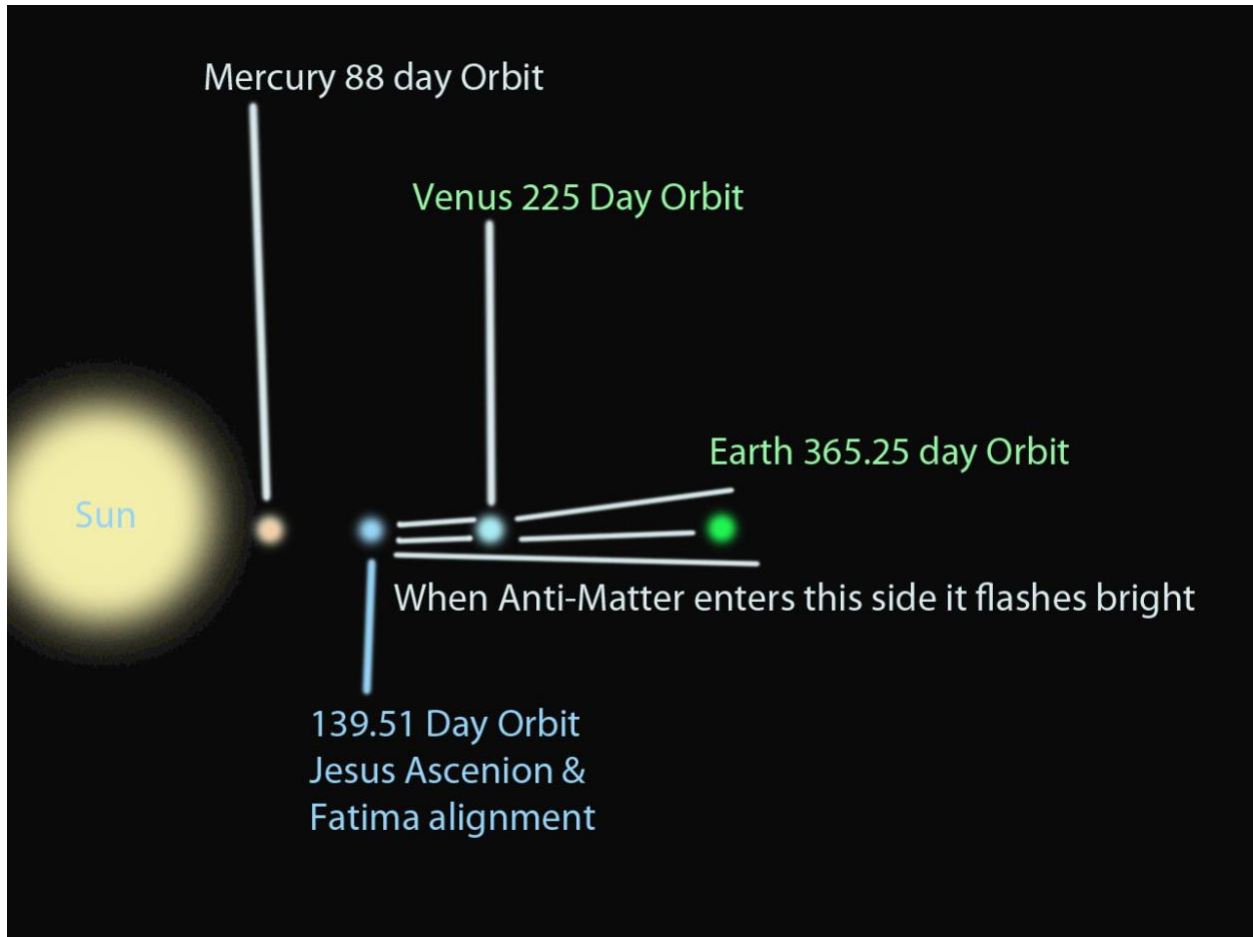

The super bright flashes of light coming from the “Ascension Planet” during the October 13th, 1917 miracle of the sun were not the sun at all. The orbit of this planet would be a little more than Mercury’s and a little less than Venus. The flashing would come from the alignment of the sun and the “Ascension Planet” possibly during it’s “transit” across the face of the sun in perfect timing.

January 1, 1917, to the date of the first vision of Mary to the children on May 13th, 1917 was 133 days so the “Ascension Planet” made 1 orbit around the sun and on October 13th, 1917, it made a 2nd Orbit around the sun accurate to better than 96%! Do we see how profound this information is? December 25th, as a start point gave us better than 99% accuracy!

When the “Miracle of the Sun happened” the Ascension Planet was beaming us on Earth with its real, physical light signal and no one noticed until now. If light from Venus to Earth takes 3 minutes and 43 seconds, the light from the “Ascension Planet” to earth would be 1.618 times that, which is exactly 6 minutes from Earth!

It is 6 minutes away from us for a radio signal! Wait, 6 minutes exactly? Do we know what this means?

The facts prove that this planet is real! Why does it elude us? Why does it become visible periodically, or by precise control or cloaking, which is predicted in the book of Revelation, Chapter 21: “Now I saw a new heaven and a new earth, for the first heaven and the first earth had passed away.”

The “New Heaven” is now upon us! We know where it is. Using sophisticated computer planetary orbital monitoring, we can know where it is at any time and send it a radio message to let it know “we have found you” and we are with eyes open to the greatest secret of all time!

How could a “new heaven” just suddenly appear – a whole sphere or planet just suddenly? There is only 1 explanation and that is anti-matter, antimatter planets and a hidden antimatter solar system and antimatter persons that are right in our midst!

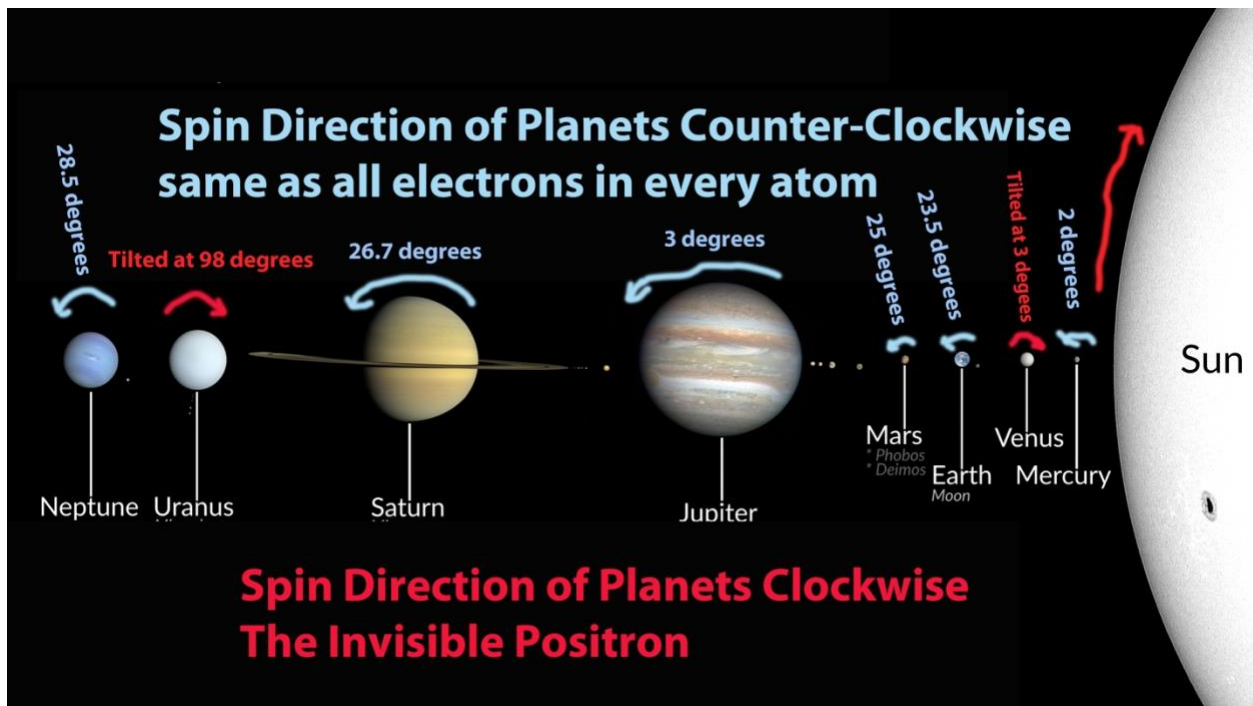

Antimatter and antimatter Planets!

In 1936, at age 31, Carl David Anderson became the second youngest Nobel laureate for his discovery of antimatter when he observed positrons in a cloud

chamber. Antimatter is “invisible” as are its constituent planets and people. Antimatter only appears at very high energies when atomic particles are accelerated to over 95% the speed of light, or when gamma rays (the highest frequency light we have discovered thus far) give birth to antimatter! The Earth always has a tiny amount of antimatter coming into existence and going out of existence due to lightning strikes!

Paul Dirac, shared the 1933 Nobel Prize in Physics with Erwin Schrödinger "for the discovery of new productive forms of atomic theory". He also made significant contributions to the reconciliation of general relativity with quantum mechanics. Dirac, on why the positron was not discovered until 1932:

"Why did the experimentalists not see them? Because they were prejudiced against them. The experimentalists had been doing lots of experiments where particles were moving along curved tracks in a magnetic field. [They] sometimes saw the opposite curvature, and interpreted the tracks as electrons which happened to be moving into the source, instead of the positively charged particles coming out. That was the general feeling. People were so prejudiced against new particles that they never examined the statistics of these particles entering the source to see that there were really too many of them." -- Dirac, in J. Mehra, ed. **The Physicist's Conception of Nature**, pg. 12.

Being prejudice, as Dirac exclaims, is due to being myopic and not looking at the data right in front of us! It took too many years then to see it! Today, the topic of anti-persons and anti-planets to anti matter galaxies is being discussed because shortly after the big bang model, there were equal amount of both matter and antimatter. The problem is, no one really knows mathematically where all that antimatter went. All that is known is that at these very high energies, antimatter shows up in the mirror!

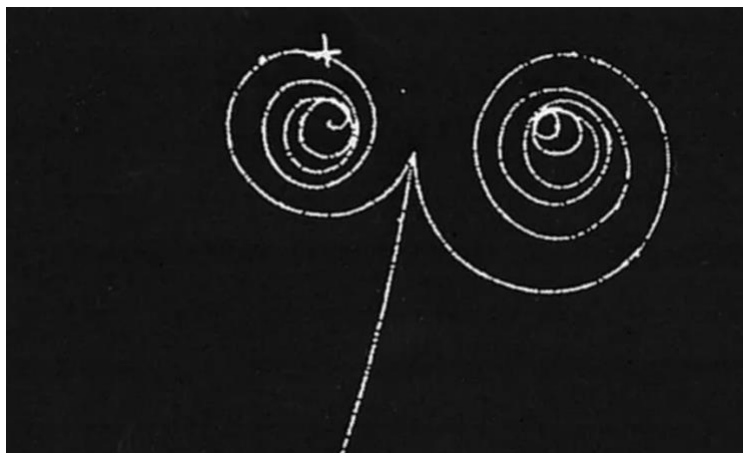

Electron Left – Positron right

The 591 divided by and multiplied by the Golden Ratio formula shows where exactly those antimatter planets should be right inside of our own solar system.

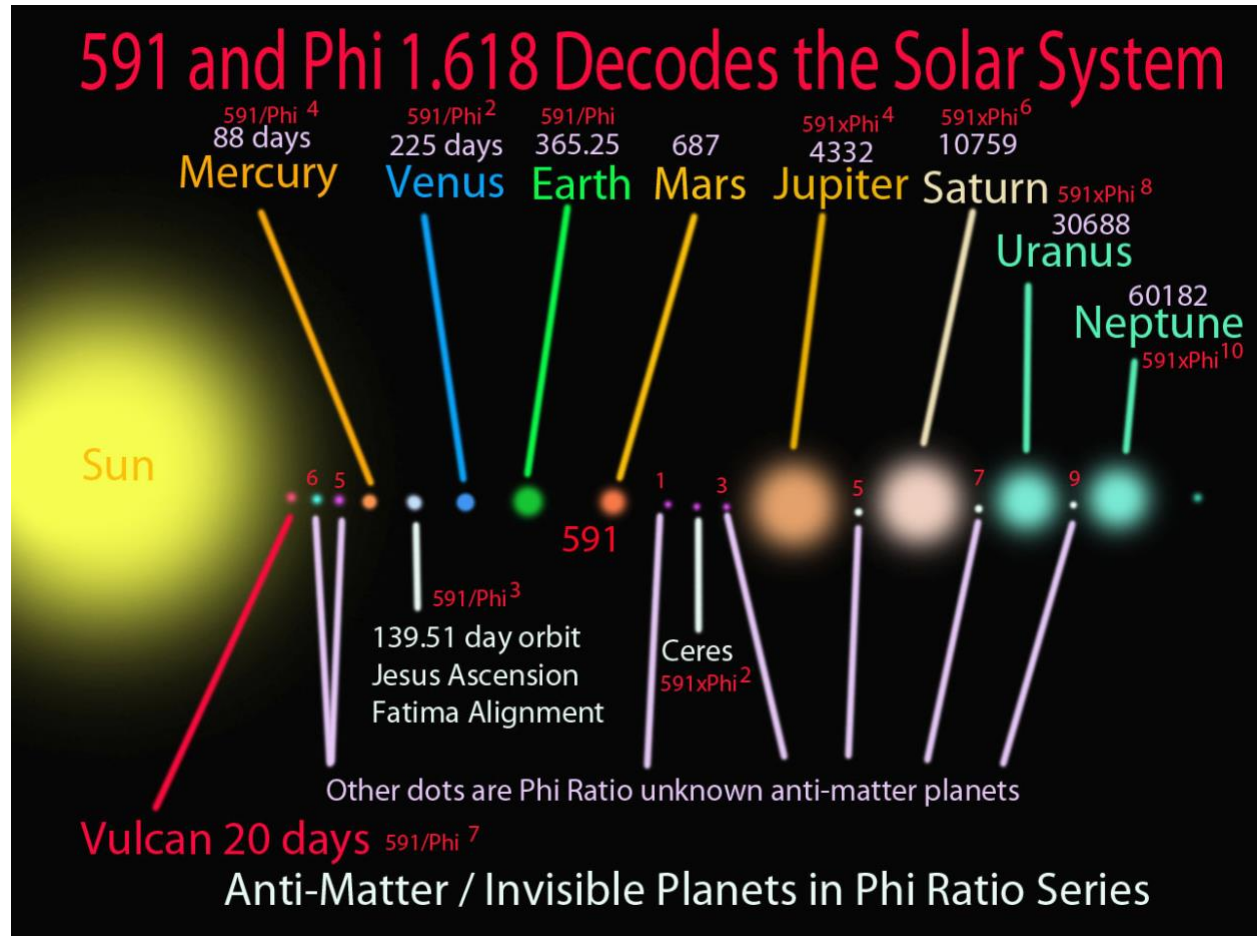

If I include every single point in the 591 divided by the golden ratio, we see in the illustration, the known visible planets and the invisible antimatter theoretical planets with their invisible periods of rotation around the sun. The 139.51 is marked between Venus and Mercury, yet 3 more invisible planets appear between Mercury and the Sun! Planet Vulcan is the closest to the sun, also known as having been a theoretical planet with an orbit near 20 days that fits the 591 model to a very high degree of accuracy! More on planet Vulcan later after we resolve what the Bible coincides with Mercury in the book of Revelation!

Revelation Chapter 21 describes the New Jerusalem, Cubic City of God, 1,500 miles cubed, coming out of the sky and down upon the earth at the end of the

tribulations. This is a huge object that may be what resides in between Venus and Mercury!

Mercury's diameter is 3,000 miles, which is exactly twice the breadth of the Cubic City of God in Revelation! The radius of Mercury is 1,500 miles.

The radius of Mercury is the same measurement as the Cubic City of God!. That is an astounding coincidence! If we make a 2 and then 3 dimensional cube out of the radius of Mercury, we have the dimensions for the new Jerusalem, or city of God!

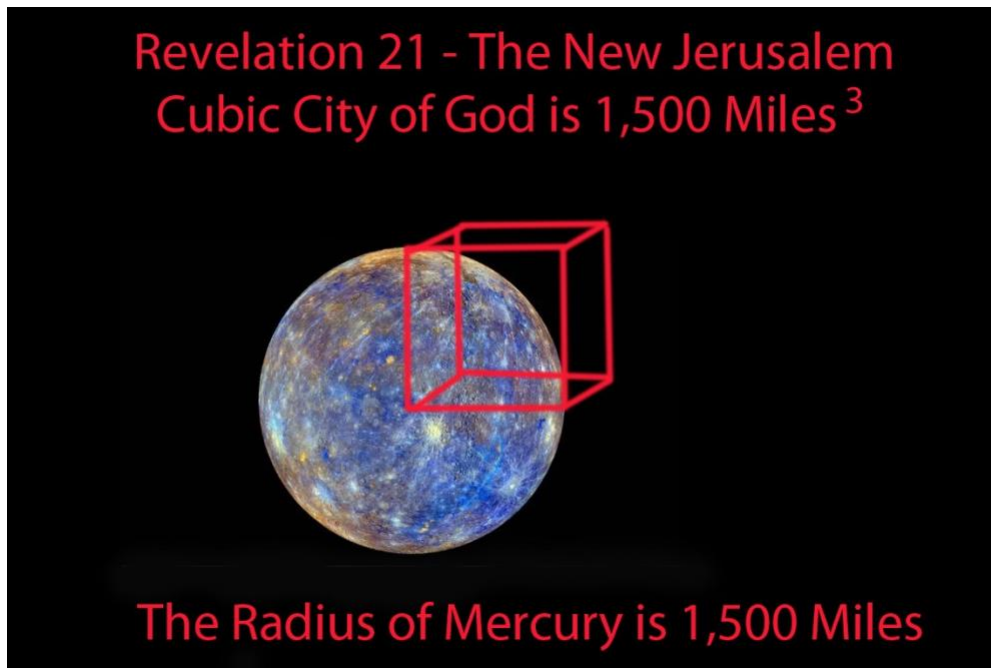

This is how we square the circle traditionally. Radius squared x Pi (3.14159) = If we were to want to know the square of the circle of Mercury. Why does the Cubic City of God that is to come upon the earth at the end of the Revelation have a perfect function of Mercury's Square and cubic volume unless it is a significant understanding?

Now we take the 139.516174702375671 Earth Days per year for the missing planet divided by the Golden Ratio 1.618033988749895 = Mercury at 86.225737946436402 Earth days per year accurate to 97.98% (Mercury is out 2.2%) from the War in Heaven!

What the War in Heaven did by disturbing the vibrations between the planets and taking them from a perfect harmony to an out of phase vibration had an immense impact on the human consciousness!

This would explain as we continue the Golden Ratio Sequence from 591 to the outer planets of Jupiter, Saturn, Uranus and Neptune why they are slightly out of phase with the Golden Ratio, but still within “tolerance”!

The Babylonian myth, the “Enuma Elis” involved an incoming planetary body that destroyed a planet between Mars and Jupiter and created other havoc among the spheres in the solar system as well as the asteroid belt. Could this explain the lack of total perfection, but still tolerance?

There is so much astronomers do not know about what happened in this solar system!

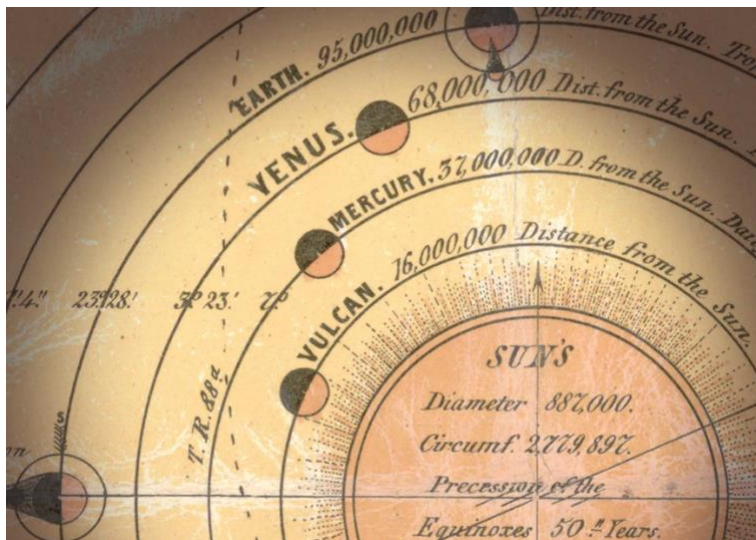

Planet Vulcan Lithograph Map from 1846

Mysteriously, another unconfirmed planet was discovered closer to the sun than Mercury in the late 19th century: Le Verrier was not happy about Lescarbault's crude equipment but was satisfied the physician had seen the transit of a previously unknown planet. On 2 January 1860 he announced the discovery of the new planet with the proposed name from mythology, "Vulcan", at the meeting of the [Académie des Sciences](#) in Paris. Lescarbault, for his part, was awarded the [Légion d'honneur](#) and invited to appear before numerous learned societies.

Based on Lescarbault's "transit", Le Verrier computed Vulcan's orbit: it supposedly revolved about the Sun in a nearly circular orbit at a distance of 21 million kilometres (0.14 AU; 13,000,000 mi). The period of revolution was 19.708 days!

Guess what? If I take 591 divided by the Golden ratio 1.618033988749895 7 times, I pass all the inner planets and I get to an orbital period of 20.355135565442105 days = which is accurate to planet Vulcan's orbit to 96.82% - a fact so stunning, we can only speculate 2 possibilities: 1. Vulcan is one of NASA's greatest kept secrets or 2. Vulcan goes INVISIBLE and becomes VISIBLE again over periods of time! Why does the Golden ratio say there is supposed to be a planet there?

Why did NASA allow planet Vulcan to be disproved in 1915 with Einstein's equations on gravity anomalies?

Vulcan is the Roman god of fire and forging of metals mythically representing a planet closer to the sun than Mercury, the "Messenger" god. Hephaestus is his Greek equivalent.

Of course we have all heard that "Spock" from Star Trek came from planet "Vulcan" but is there a greater mystery to how Star Trek used ancient myth?

I found out last night, April 11, 2023, when I made an online purchase, my credit card security code is 591 - I got this new card and number months after Crystal died because our daughter Alyra Sereda lost my old one. Now what are the odds? This is a physical manifestation that confirms that afterlife contact with Crystal!

All of this comes from Crystal Sereda's vision to David Sereda on March 23rd, 2023 (3 days into the Spring Equinox) 591 days after she died, August 9, 2021!

Update: Today is July 1, 2023 and I heard Crystal's VOICE this morning sounding like it was coming from a portal above. I have been doing the frequencies of Venus for 3 days now. The voice was literally sounding like it was piercing our dimension through a portal. I counted the days from her death from August 9, 2021 to July 1, 2023 = 691 days. WOW again because our last number that decoded the solar system was 591 and now we have 691. What does this mean? I will figure it out.

January 7 (Orthodox Christmas) to July 1 is 176 days, which is exactly equal to 2 orbits of the planet Mercury (88 days per orbit) – knowing that the start point for new solar years can range from December 25 to January 7th with these experiences. Why again to we have such accuracy to the planetary rotational bodies with these spiritual experiences? The answer is going to become astounding!

From statistica:

Today, the vast majority of the world uses what is known as the Gregorian calendar, Named after Pope Gregory XIII, who introduced it in 1582. The Gregorian calendar replaced the Julian calendar, which had been the most used calendar in Europe until this point. The Gregorian calendar lasts for approximately 365.24 days; this means that most years have 365 days, with one extra day being added every fourth year, unless the year is divisible by 100 but not 400 (for example, the year 2000 was a leap year, whereas 2100 and 2200 will not be).

That is why we have tolerance mathematically. Mars currently has an orbital period of earth 687 days to go around the sun and experience 1 year. 691 is 99.421 % accurate to Mars expressed as Dante's 4th level of Heaven! The 591 decoded the whole solar system to a high degree of accuracy and was most likely the original position of Mars.

Crystal could also be confirming that 591 was the original position of Mars because without that number, the Golden Ratio would not work to decode the whole solar system. 691 only decodes the current position of Mars to a very high degree of accuracy.

Interesting also that $691/432 = 1.6 =$ The golden ratio accurate to Fibonacci 8/5 ratio as in 1,1,2,3,5,8,13,21,34,... Fibonacci's infinite expression!

If we study some of the most visible public sightings of the Mother Mary since the time of the resurrection of Christ in the modern era, we will see the pattern emerge with stunning clarity.

Marian Apparitions Coincide with the planets!



https://en.wikipedia.org/wiki/Our_Lady_of_Medjugorje

<https://medjugorje.com/your-local-apparition-time/>

Is the Virgin Mary still appearing in Medjugorje?

Yes, the Virgin Mary still appears daily to Marija Pavlovic, Ivan Dragegivic, and Vicka Ivankovic. The Virgin Mary appears to Mirjana Soldo, every March 18. Jakov Colo receives an apparition on December 25 each year and Ivanka Ivankovic receives an apparition of the Virgin Mary on June 25 each year.

What time does Our Lady appear in Medjugorje?

Our Lady appears daily at 5:40 PM, Medjugorje time in the winter, and at 6:40 PM during daylight savings time in Medjugorje. This is the daily apparition time seen in the charts below. The other times Our Lady appears on special occasions, such as to Mirjana on March 18, Jakov's annual apparition on Christmas and Ivanka's annual apparition on June 25, are usually at other times, earlier in the day. Our Lady also appears during Ivan's prayer group meetings, later in the evenings. Please see the note below about daily the apparition time.

The first apparition was June 25, 1981 - so look at the 3 dates above from the website:

December 25 (within the new annual sun window) March 18, = 84 days accurate to Mercury's orbit of 87.969 days = 95.48%

December 25 to June 24 (original date) = 182 days / Mercury's 87.969 = 2.06
accurate to 2 orbits of Mercury

This makes Mercury the center of these apparitions

Zeitun, Egypt apparitions 1969!

Golden ratio x Planq



Actual photo of Mary's Body of Light witnessed by over 250,000 people in Zeitun, District of Cairo, Egypt 1969

The 2 dates of Mary Apparitions April 2, 1969 to May 29, 1971 = 1152 days / Mercury 87.969 = 13.09 orbits around the sun of Mercury illustrating a perfect function of Mercury

13 is a Fibonacci number as in 1, 1, 2, 3,5,8,13, 21 so for every 13 orbits of Mercury, Planet 139.51 will make 5 which is also a Fibonacci number, which means they are Golden Ratio squared apart in a Fibonacci harmonic!

In the Orthodox, Jan 7 (Christmas Day in the window of the new annual sun) to April 2 is 86 days = 97.77% accurate to 1 Mercury Orbit

In the Orthodox, Jan 7 (Christmas Day in the window of the new annual sun) to May 29 is 143 days, accurate to Planet 139.51 to 97.56 % The Zeitun apparitions illustrate Mary coming in on a harmonic of Mercury and going out on a harmonic of the ascension planet of Jesus - demonstrating the twin to Mercury and the ascension dates of Jesus and the ascension planet 139.51 position!

Assiut Egypt Apparitions 2000



Started August 17, 2000 reported on CNN, NBC and other world news sources

January 6 (which is early orthodox Christmas) to August 17 is 224 days. Venus is 225 days - which makes this apparition in near perfect concert to Venus at 99.55% accuracy!

This once again demonstrates Venus as a platform of God's throne as Jesus called in Revelation 22:16

My wife Crystal died August 9, 2021. December 25th to August 9 is 228 days, which is a near perfect harmonic of the Planet Venus 225 days. 225 is to 228 is 98.68% accuracy!

David Sereda